

**Sensor for safeguarding
of press brakes
V 4000 Press Brake**

SICK

This document is protected by copyright. The SICK AG company retains this right. Reproducing this document in whole or part is only permissible within the limits of the statutory regulations of copyright law. Modifying or abridging the document is impermissible without the express written permission of from the SICK AG company.



Contents

1	About this document.....	6
1.1	Function of this document	6
1.2	Target groups.....	6
1.3	Scope	6
1.4	Depth of information	6
1.5	Abbreviations.....	7
1.6	Symbols used.....	8
2	On safety.....	10
2.1	Specialist personnel	10
2.2	Areas of application of the device	10
2.3	Correct use of the device	11
2.4	General protective notes and protective measures	11
2.5	Safety in operation	12
2.6	Environmental protection.....	17
2.6.1	Disposal	17
3	Product description	18
3.1	Special features.....	18
3.2	Safety concept.....	19
3.2.1	Protection principle of the V 4000 PB	19
3.2.2	Protective volume during the operating cycle	21
3.2.3	Intrusion of the protective volume during the operating cycle	22
3.3	Range of use.....	23
3.4	Structure of the device.....	24
3.4.1	Sender and receiver.....	24
3.4.2	Displays at the sender and receiver.....	25
3.4.3	Interfaces at the receiver.....	27
3.4.4	PBI (press brake interface).....	29
3.4.5	CDS (Configuration & Diagnostics Software).....	30
3.4.6	External operating elements	32
3.5	Possible device configurations	32
3.5.1	Source of the operator signals	34
3.5.2	Baud rate communication interface	34
3.5.3	Application name	34
3.5.4	Repetition interval of power-up cycle.....	34
3.5.5	Mounting of receiver	35
3.5.6	Speed-dependent muting	35
3.5.7	Position-sensing system	35
3.5.8	External device monitoring (EDM).....	36
3.5.9	Default value for braking distance.....	36
3.5.10	Travel for determining the braking distance.....	37
3.5.11	Braking offset.....	37
3.5.12	Target speed v_{slow} for determining the braking distance	37
3.5.13	Maximum closing speed and maximum overall machine overrun.....	38
3.5.14	Travel for determining the overall machine overrun	39
3.5.15	Standstill time for determining the top dead centre.....	39
3.5.16	Start delay for closing movement.....	39
3.5.17	Time for standstill detection.....	40
3.5.18	Settling times for inputs.....	40
3.5.19	Discrepancy times for inputs.....	41

3.5.20	Start signal with reduced protective volume (double-click).....	41
3.5.21	Minimum state time for standard outputs	42
3.5.22	Minimum switch-off time for safety-relevant outputs	42
3.5.23	Bypass	42
3.6	Protective operation.....	43
3.6.1	Power-up cycle	43
3.6.2	Teach-in	44
3.6.3	Protective volume modes in protective operation	44
3.7	System sequences in protective operation	47
3.7.1	Power-up cycle in standard mode.....	48
3.7.2	Teach-in	52
3.7.3	Standard mode	54
3.7.4	Box mode	56
3.7.5	Back-stop mode.....	58
3.8	Alignment mode	60
4	Mounting.....	61
4.1	Steps for mounting	61
4.1.1	Mounting the sender or receiver using SICK mounting kit 1	61
4.1.2	Mounting the sender or receiver using SICK mounting kit 2	62
4.1.3	Sticker: Information for daily inspection.....	63
5	Electrical installation	64
5.1	Connecting the receiver.....	64
5.2	Connecting the sender.....	67
5.3	Making up the connections for receiver and sender	68
5.4	Connecting the PBI.....	68
5.5	External device monitoring (EDM).....	70
5.6	Bypass	71
5.7	Configuration connection (serial interface)	72
6	Configuration	73
6.1	Delivery state.....	73
6.2	Configuration preparations.....	74
7	Commissioning.....	75
7.1	Test notes	75
7.2	Aligning sender and receiver	75
7.2.1	Initial alignment.....	75
7.2.2	Alignment following a tooling change.....	82
7.3	Function check.....	84
7.4	Regular checks of the protective device by specialist personnel	87
7.5	Daily checks of the protective device by authorised commissioned persons	87
8	Operation	89
8.1	Switching the machine on	89
8.2	Selecting protective volume mode.....	90
8.3	Resetting.....	90
8.4	Carrying out a power-up cycle.....	90
8.5	Carrying out teach-in	92
8.6	Bending in standard mode	93
8.7	Bending in box mode	93
8.8	Bending in back-stop mode.....	93

8.9	Changing the sheet thickness	93
8.10	Tool changing.....	94
8.11	Care and maintenance.....	94
9	Diagnostics	95
9.1	Response to errors and malfunctions	95
9.2	Error displays of the LEDs	95
9.3	Error displays of the 7-segment display	96
9.4	Extended diagnostics via CDS	98
9.5	SICK support.....	99
10	Technical data.....	100
10.1	Device data sheet.....	100
10.1.1	V 4000 PB technical data.....	100
10.1.2	Technical data for PBI (press brake interface)	106
10.1.3	Incremental encoder technical data	107
10.2	Dimensional drawings	108
10.2.1	Sender and receiver.....	108
10.2.2	SICK mounting kit 1	109
11	Ordering information	110
11.1	Scope of delivery	110
11.2	Available systems	110
11.3	Accessories	110
12	Glossary.....	112
13	Annex.....	115
13.1	Detailed system sequences in protective operation	115
13.1.1	Power-up cycle.....	116
13.1.2	Teach-in	118
13.1.3	Standard mode.....	120
13.1.4	Box or back-stop mode with interruption of the protective volume	122
13.2	Declaration of Conformity	124
13.3	Manufacturer's checklist.....	126
13.4	List of tables	127
13.5	List of illustrations	128
13.6	Index.....	130

1 About this document

Read this chapter carefully before working with the operating instructions and the V 4000 Press Brake sensor.

For "V 4000 Press Brake" we shall use the abbreviation "V 4000 PB" from now on.

1.1 Function of this document

These operating instructions are intended for *the technical personnel of the machine manufacturer* or the *machine operator* in regards to safe mounting, electrical installation, configuration, commissioning, operation and diagnostics of the V 4000 PB sensor.

These operating instructions do *not* provide instructions for operating machines on which the V 4000 PB is, or will be, integrated. Information of this kind will be found in the operating instructions for the machine.

1.2 Target groups

These operating instructions are intended for *manufacturers, operators and the users* of press brakes which are to be protected by a V 4000 PB sensor. It also addresses people who integrate the V 4000 PB sensor into a machine, commission it initially or who are in charge of servicing and maintaining the unit.

1.3 Scope

Note These operating instructions apply for the V 4000 PB sensor with the following type label entry in the *Operating Instructions* field: 8 010 501. This document is part of SICK part number 8 010 501 (V 4000 PB sensor operating instructions in all available languages). You will require a CDS (Configuration & Diagnostic Software) version 3.0 or greater for the configuration and diagnostics of this device. To determine the software version, select the **Module info** item from the ? menu in the menu bar.

1.4 Depth of information

These operating instructions contain information on the V 4000 PB sensor regarding the following subjects:

- Mounting
- Electrical installation
- Configuration and commissioning
- Operation, care and maintenance
- Error diagnostics and remedying
- Technical data and order numbers
- Conformity and approval

Planning and using protective devices such as the V 4000 PB sensor also require specific technical skills which are not detailed in these operating instructions.

When operating the V 4000 PB sensor, the national, local and statutory rules and regulations must be observed.

General information on health and safety using opto-electronic protective devices is contained in the brochure "Safe Machines with Opto-Electronic Protective Devices".

V 4000 PB

Note We also refer you to the SICK homepage on the Internet at
<http://www.sick.com>

Here you will find:

- These operating instructions in different languages for viewing and printing
- The EC Declaration of Conformity

1.5 Abbreviations

ANSI	American National Standards Institute
BWS	Electro-sensitive protective equipment (ESPE) (e.g. V 4000 PB)
CDS	SICK Configuration & Diagnostic Software = software for configuring and diagnosing the V 4000 PB sensor
EDM	External device monitoring
ESPE	Electro-sensitive protective equipment
HMI	Human machine interface
LD	Laser diode
LED	Light-emitting diode
MP	Muting point
NC	Numerical control
OMO	Overall machine overrun
ORT	Overall response time
OSSD	Output signal switching device = signal output of the protective device to the controller used for switching off the movement which is the source of danger
PBDC	Programmed bottom dead centre
PBI	Press brake interface
PTDC	Programmed top dead centre
PP	Pinch point
SP	Switch-over point
SPLC	Safety programmable logic control
V 4000 PB	V 4000 Press Brake

1.6 Symbols used

Recommendation Recommendations are designed to provide some assistance for your decision-making process regarding application of a certain function or technical measure.

Note Notes provide special information about the device.

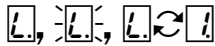

Display indicators show the status of the 7-segment display of the receiver:

- Constant display of the letter F
- Flashing display of the letter F
- Alternating display of F and 2

● **Yellow**, **Yellow**,
○ **Yellow**

LED symbols describe the state of an LED:

- The LED is illuminated constantly.
- The LED is flashing.
- The LED is off.

■, □ ON or OFF state:

- ON
- OFF

➤ **Action ...** Instructions for taking action are shown by an arrow. Read carefully and follow the instructions for action.



WARNING

Warning!

A warning indicates concrete or potential dangers. They save you from harm.

Read warnings carefully and abide by them!



Software notes show the location in the CDS (Configuration & Diagnostic Software) where you can make the appropriate settings and adjustments. Go to the **View** menu, **Dialogue windows** of the CDS and activate the **item tabs** to view the named dialogue boxes as required. Otherwise use the software wizard to make the desired settings.



Sender and receiver

In drawings and diagrams, the symbol denotes the sender and the symbol the receiver.

The term "dangerous state"

In the drawings in these operating instructions, the dangerous state (standard term) of the machine is always represented as a movement of a machine part. In practical operation there may be a number of different dangerous states:

- Machine movements
- Electrical conductors
- Visible or invisible radiation
- A combination of several risks and hazards

Representation of the signals for teach-in, alignment mode and selection of protective volume mode

These operating instructions also describe the V 4000 PB input and output signals. As a way of uniquely representing the signals for teach-in, alignment mode and selection of protective volume mode (input signals), tactile switching amplifiers (buttons, switches) are used. The signals can be generated at the inputs of the V 4000 PB by, for example, foot switches, alignment buttons, teach-in buttons, selector switches and key-operated switches or by the corresponding switching elements on the MMI of the press controller.

2 On safety

This chapter deals with your own safety and the safety of the operators.

- Read this chapter carefully before working with the V 4000 PB or with the machine protected by the V 4000 PB.

2.1 Specialist personnel

The V 4000 PB must be mounted, connected, commissioned and serviced only by specialist personnel. Specialist personnel are defined as persons who

- due to their technical training and experience possess sufficient knowledge in the field of safety equipment for making press brakes safe

and

- who have been instructed by the responsible machine operator in the operation of the machine and the current valid safety guidelines

and

- have sufficient familiarity with the relevant national industrial safety regulations, work safety regulations, directives and the generally recognised code of practice of the industry (for example, DIN standards, VDE specifications, technical codes of other EC member states) that they can judge whether the press brake is safe from the occupational safety point of view

and

- have access to and have read these operating instructions.

As a rule these will be specialist personnel, the manufacturer of the ESPE or even such persons who have been given the corresponding training by the ESPE manufacturer, who are mainly concerned with inspecting and testing ESPEs and have been commissioned by the ESPE operator in this regard.

2.2 Areas of application of the device

The V 4000 PB is an ESPE (electro-sensitive protective equipment) device designed to protect the area beneath the die of press brakes at high closing speeds. As soon as an object enters the protective volume beneath the die, the ESPE issues the signal to the press controller to stop the fast closing movement and this system must then stop the closing movement.

The V 4000 PB consists of a sender and a receiver which are mounted on the press crosshead. The protective volume between the sender and the receiver moves with the press crosshead and thus ensures that the safeguarded area stays beneath the die.

The device is a *Type 4 ESPE* as defined by IEC 61 496-1 and 2 and is therefore allowed for use with controls of safety category 4 in compliance with EN 954-1.

V 4000 PB

Use of the V 4000 PB in the open air or explosion hazard areas is not permitted. The V 4000 PB can only be used in normal industrial environments.



Only use the V 4000 PB as an indirect protective measure.

An opto-electronic protective device provides indirect protection, e.g., by switching off the power at the source of the hazard. It cannot provide protection neither from parts thrown out, nor from emitted radiation. Transparent objects are not detected.

Depending on its applications, mechanical protective devices may be needed in addition to the V 4000 PB.

2.3 Correct use of the device

The V 4000 PB is intended to be used solely at a fixed location on press brakes and may only be used as defined by Section 2.2 "Areas of application of the device". It must be used only by specialist personnel and only on the machine where it has been mounted and initially commissioned by specialist personnel in accordance with these operating instructions.

SICK AG accepts no claims for liability if the equipment is used in any other way or if modifications are made to the device, even in the context of mounting and installation.

2.4 General protective notes and protective measures



Protective notes

Please observe the following protective notes in order to ensure the correct and safe use of the V 4000 PB.

- Warnings on the V 4000 PB must be observed without fail.
- The V 4000 PB meets the requirements of laser protection class 1 M. Do not look into the laser beam neither with the naked eye nor using optical equipment (such as binoculars).

Fig. 1: Warning regarding laser class 1M



- This device meets the norms: CDRH 21 CFR 1040.10, 1040.11 as well as DIN EN 60825:2001. There the following note is required: "Caution – use of controls or adjustments or performance of procedures other than those specified herein may result in hazardous radiation exposure!"
- The V 4000 PB may not be dismantled for repair. A defective unit must be returned to the manufacturer.

- The national/international rules and regulations apply to the installation, commissioning and periodic technical inspections of the V 4000 PB, in particular:
 - Machinery Directive 98/37/EC
 - Provision and use of Work Equipment Directive 89/655/EEC
 - The work safety regulations/safety rules
 - Relevant national health and safety regulations
 Manufacturers and operators of the machine on which the V 4000 PB is used are responsible for obtaining and observing all applicable safety regulations and rules.
- The notices, in particular the test regulations (see Chapter 7 "Commissioning") of these operating instructions (e.g. on use, mounting, installation or integration into the existing machine controller) must be observed.
- The tests must be carried out by specialist personnel or specially qualified and authorised personnel and must be recorded and documented to ensure that the tests can be reconstructed and retraced at any time.
- The operating instructions must be made available to the operator of the machine where the V 4000 PB is fitted. The machine operator is to be instructed in the use of the device by specialist personnel and must be instructed to read the operating instructions of the V 4000 PB and of the machine.

2.5 Safety in operation



WARNING

Dangers which the V 4000 PB does not protect against!

The different ways in which the press brake can be used in manufacturing means that indirect dangers may arise.

Please observe and comply with the following points in order to protect yourself against dangers during machine operation.

The V 4000 PB safeguards the hazardous point beneath the die at high closing speeds (over 10 mm/s) or irrespective of the speed up to a gap of 6 mm. The maximum height of the protective volume up to the lower edge of the die is 26 mm.

Maximum protection is provided in standard protective volume mode.

In the case of box-bending or back-stop operation, use of a restricted protective volume is possible. With this kind of work, the reduced dimensions of the protective volume means that only limited protection against getting caught or crushed is possible.

If parts of the body are brought into the hazardous point within a box, they will only be detected behind the tolerance zone around the pressure axis. There is a danger of injury by being caught or crushed.

For a time interval of 100–150 ms (just before the gap height of 6 mm is reached) there is the possibility of an object which is moving into the space between the die and the workpiece being crushed.

Correct handling of the workpiece

By handling the sheet properly you can avoid your hands or fingers being caught or crushed.

V 4000 PB

➤ Use gloves to prevent:

- Injuries caused by edges, corners and burr
- Residues and rust caused by sweat from the hands getting on dies and workpieces
- Deposits on the hands
- Slipping of smooth workpieces

Fig. 2: Handling of the workpiece 1

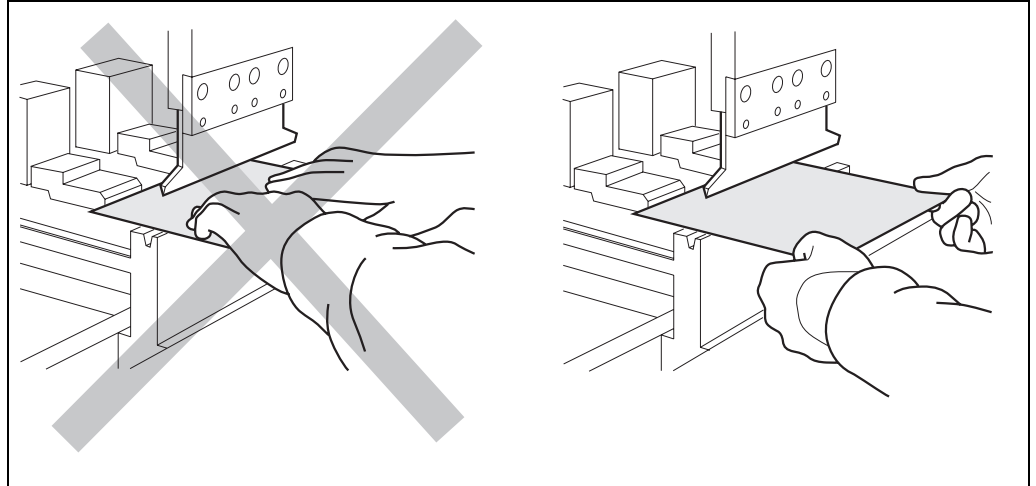

➤ Hold the sheet by the left and right corners of the end facing you.

➤ Use both hands to hold the sheet firmly from below (thumb on top of the sheet, rest of hand underneath)

Fig. 3: Handling of the workpiece 2

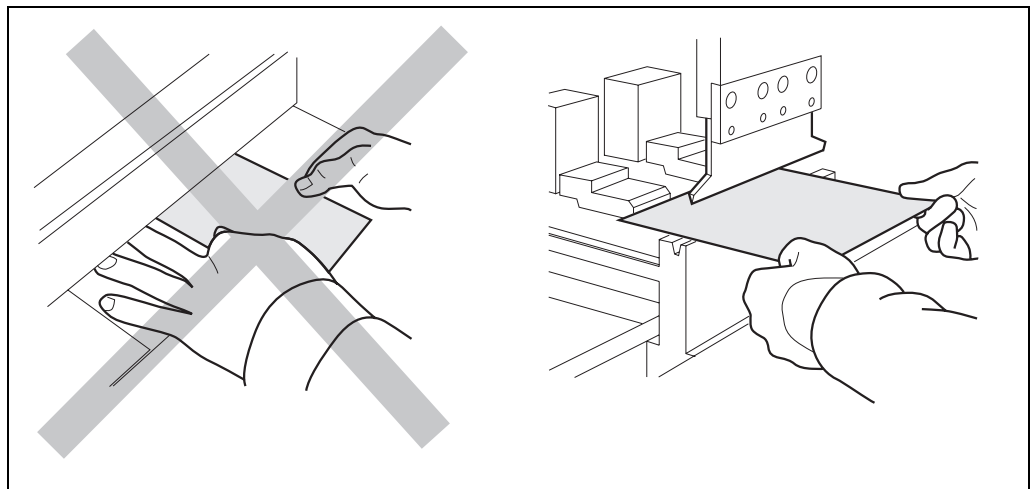

➤ When holding the sheet, be sure not to spread your fingers.

Note Spread fingers will interrupt the protective volume of the V 4000 PB. The protective function of the V 4000 PB will be triggered and the V 4000 PB initiates a stop.

If the protective volume is limited (box-bending and back-stop operation) there will be an additional risk of getting your hand caught.

Correct handling of pre-flanged sheets

Fig. 4: Handling of pre-flanged sheets

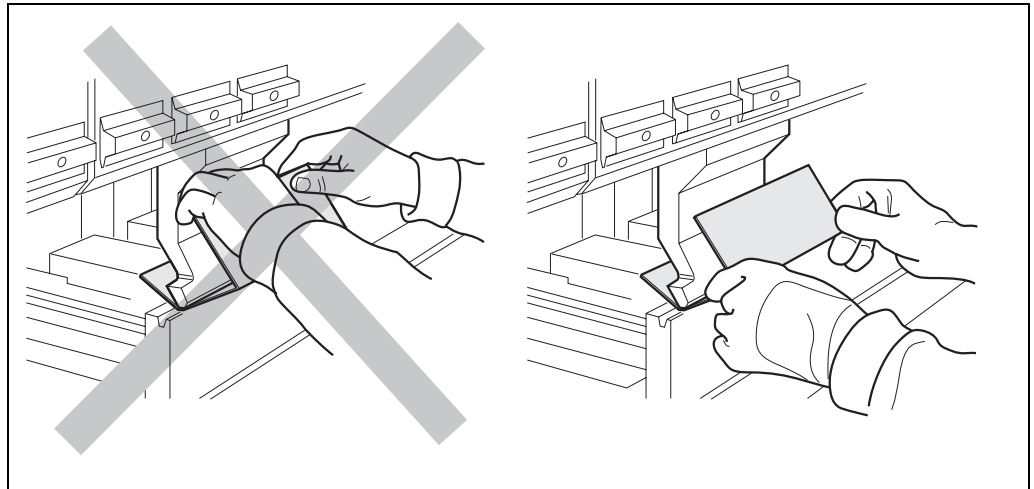

Note If pre-flanged sheets are not handled correctly, your hands could get caught between the sheet and the die or press crosshead.

- Hold the pre-flanged sheet by the left and right edges between the thumbs and index fingers.
- Use both hands to hold the sheet firmly.

V 4000 PB**Correct handling with box-bending**

Fig. 5: Handling of box-shaped workpieces

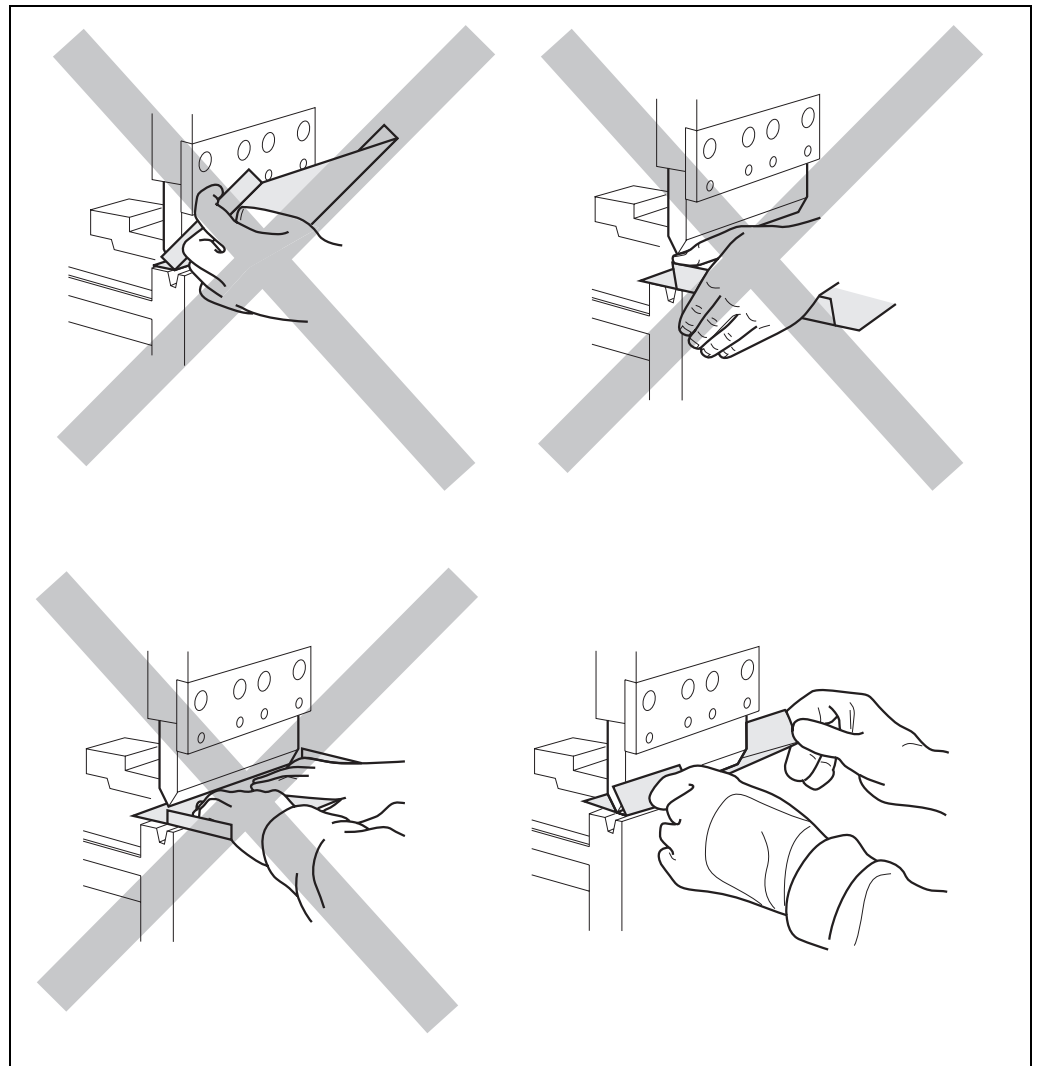

Note In box-bending and back-stop modes the protective volume is limited and a tolerance zone around the pressure axis is hidden. If box-like workpieces are not handled correctly, your hands could get caught between the workpiece and the die or press crosshead.

- Do **not** hold the upper box walls by the edges or corners on the pressure axis.
- Hold box-shaped workpieces by their back part (closest to you) outside the hazardous point.

The V 4000 PB cannot protect you against these dangers:

- Crushing your hands or fingers between the workpiece and the press crosshead as a result of handling the workpiece incorrectly during bending
- Crushing your fingers between the die and the workpiece as a result of handling the workpiece incorrectly
- The risk of injury from workpieces falling when the press brake is opened
- The risk of injury from large workpieces swinging upwards during bending
- When bending aids are used:
Risk of injury due to the workpiece swinging up or down, or to the movement of the bending aids

- When automatically traversing rear stops are used:
 - Crushing your hands or fingers between the rear stops and the female die during traversing movements towards the operator
 - The operator being crushed by large workpieces being pushed at him by the rear stops
- Risk of injury in the rear space arising from automatically traversing stops, moving tools, workpieces or bending aids.

Note Access to the rear space or standing in the rear space must be prevented by means of the appropriate safety devices, such as a light grid.

Dangers arising from mounting of the V 4000 PB

- When mounting the V 4000 PB make sure that there will be no crushing or shearing points between the moving sender and receiver and other stationary machine parts or devices in the vicinity of the machine.
- If hazardous points cannot be avoided, they must be made safe by other protective measures or remedied by design changes.

V 4000 PB

2.6 Environmental protection

The V 4000 PB has been designed to minimise environmental impact. It uses only a minimum of power and natural resources.

➤ At work, always act in an environmentally responsible manner.

2.6.1 Disposal

Disposal of unusable or irreparable devices should always occur in accordance with the applicable country-specific waste-disposal regulations (e.g. European Waste Code 16 02 14).

Before you can turn over the devices for environmentally-friendly recycling, you must separate the different materials of the V 4000 PB from one another.

➤ Separate the housing from the remaining components (especially the PCB).

➤ Press the front lens out of the lens holder.

➤ Send the separated components to the corresponding recycling centres (see Tab. 1).

Tab. 1: Overview of disposal by component

Component	Disposal
Product	
Housing	Metal recycling (aluminium)
Front lens	Glass recycling (used glass)
PCBs, cables, plugs and electrical connection pieces	Electronics recycling
Packaging	
Cardboard, paper	Paper/cardboard recycling
Polyethylene packaging	Plastic recycling

Note We would be pleased to be of assistance on the disposal of the V 4000 PB. Contact your local SICK representative.



WARNING

Material separation may only be performed by specialist personnel!

Exercise care when disassembling the devices. The danger of injury is present.

3 Product description

This chapter provides information on the special features and properties of the V 4000 PB. It describes the safety concept, the range of use, the structure and operating principle of the device, configuration options and the various operating modes.

➤ Read this chapter before you mount, install and commission the V 4000 PB.

3.1 Special features

- Sender/receiver system
- Response time 10 ms
- Unambiguous status information via LED and 7-segment display shown directly on the V 4000 PB receiver
- All inputs and outputs of the system integrated in the receiver
- Simple combination of the V 4000 PB system with alternative protective measures by means of bypass inputs and outputs
- No additional evaluation unit required in the control cabinet
- V 4000 PB system uses the existing measurement guides of the press brake for determining speed, position and direction
- Optional operation via hardware input devices or via the outputs of the press brake controller
- The SICK CDS user interface provides ease of configuration and comprehensive expanded diagnostics of the V 4000 PB system
- Reliable pinch-point monitoring even when workpiece surface has irregularities or unevenness

Automatic functions

- Determination and monitoring of the pinch point
- Monitoring of the relevant overall machine overrun of the press brake as a function of speed
- Dynamic adaptation of the switch-over point
- Position-dependent muting (6 mm above the pinch point)
- Speed-dependent muting (configurable)
- Checking of the die position to detect coarse maladjustment
- Detection of box wall in front and rear spaces

Protective operation

- 3 protective volume modes with adapted protective volume shape corresponding to bending task
- Loading of press hydraulics minimised by box and back-stop modes without emergency stop at box wall

3.2 Safety concept

3.2.1 Protection principle of the V 4000 PB

Fig. 6: Press brake with V 4000 PB

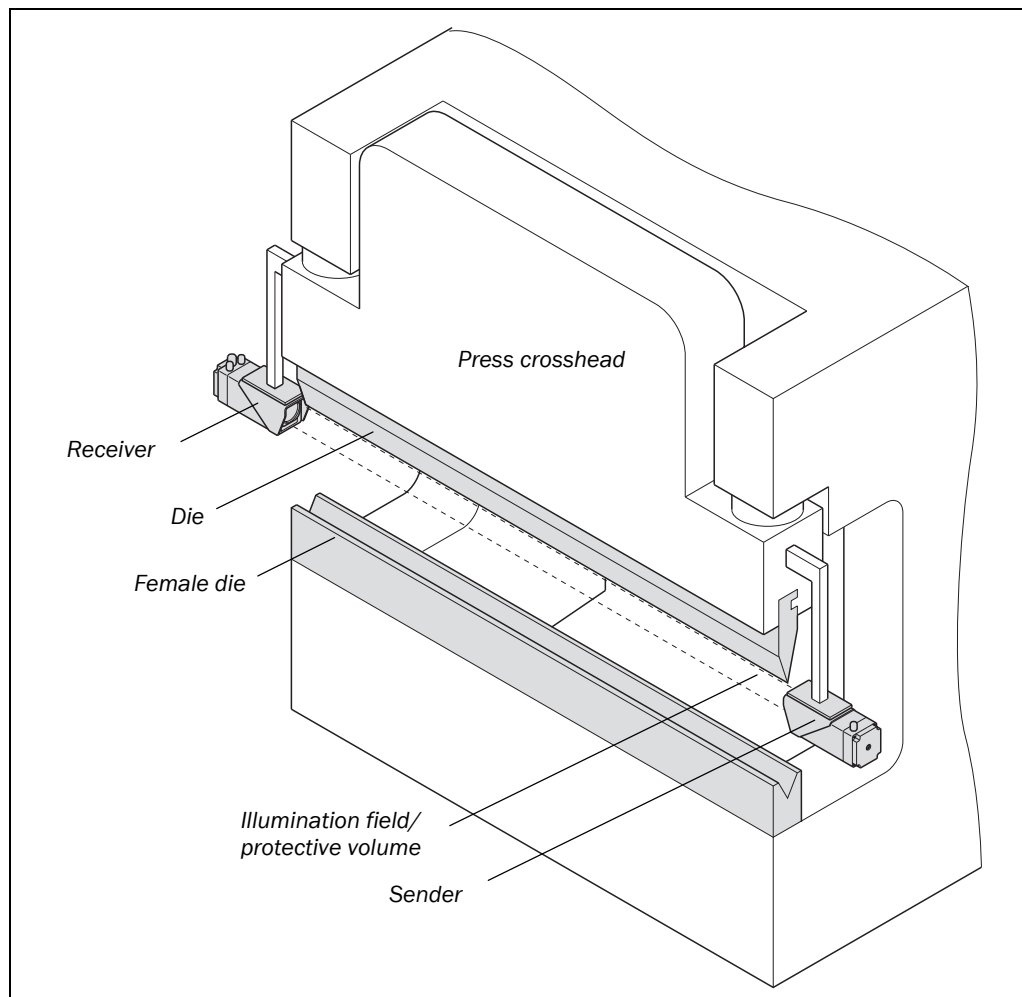

The V 4000 PB consists of a sender and a receiver mounted on the press crosshead.

A light beam of light (illumination field) between sender and receiver forms a three-dimensional protective field (protective volume) beneath the die tip measuring 40 mm wide and 26 mm high. The protective volume follows the movement of the press crosshead and in this way provides a travelling safety zone beneath the die tip.

The V 4000 PB has three different kinds of protective volume (standard, box and back-stop). These protective volumes differ in their dimensions and in their functions.

Should there be a partial or complete interruption of the protective volume by an object, the output signal switching devices (OSSDs) of the ESPE which are integrated in the receiver change over to the OFF state and generate a two-channel monitored switch-off signal to the press controller which then must stop the closing movement of the press crosshead with the die.

The evaluation and run concepts of the V 4000 PB have been designed so that the ESPE constantly checks its internal expected position (which depends on the operating mode, the press crosshead position and the speed) against the actual external situation. Only when the expected position is identical to the actual circumstances will the OSSDs remain in the ON state. Any other result will put the OSSDs into the OFF state.

The V 4000 PB safeguards the hazardous point beneath the die at high closing speeds (> 10 mm/s) and a pass-through gap height of more than 6 mm. If the gap height between the top of the workpiece and the die tip is 6 mm or less, the ESPE switches automatically into muting mode.

If the muting option is activated at a low closing speed (≤ 10 mm/s), the system will automatically go into muting mode even when the slow closing speed is reached.

In the muting state, the protective volume is inactive and the OSSDs stay in the ON state.

Note Whether muting is permitted at the slow closing speed varies from country to country. This option is by default disabled in the configuration.

In the event of system errors (such as an error being detected when the hardware is tested) the V 4000 PB switches into lock-out state.

Fig. 7: Definitions

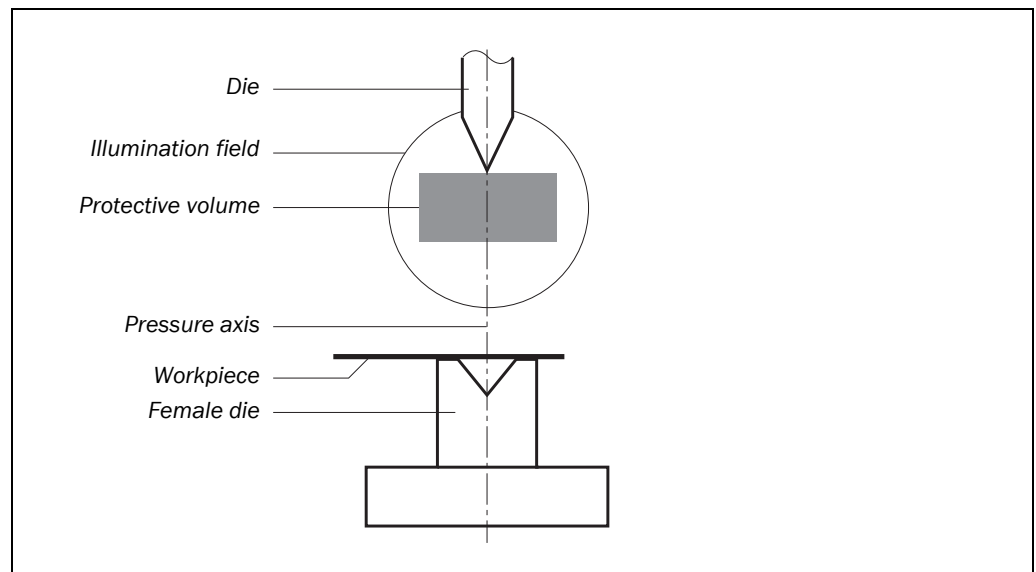

3.2.2 Protective volume during the operating cycle

This sequence shows the protective volume during one operating cycle.

- Step ①** The die is at the programmed top dead centre. The operator gives the signal to start the closing movement (foot switch).
- Step ②** The die descends at high speed (> 10 mm/s). The entire protective volume is active.
- Step ③** At the switch-over point the target speed is requested by the V 4000 PB. The press controller initiates the braking procedure. The protective volume stays active in the gap opening.

Protective volume

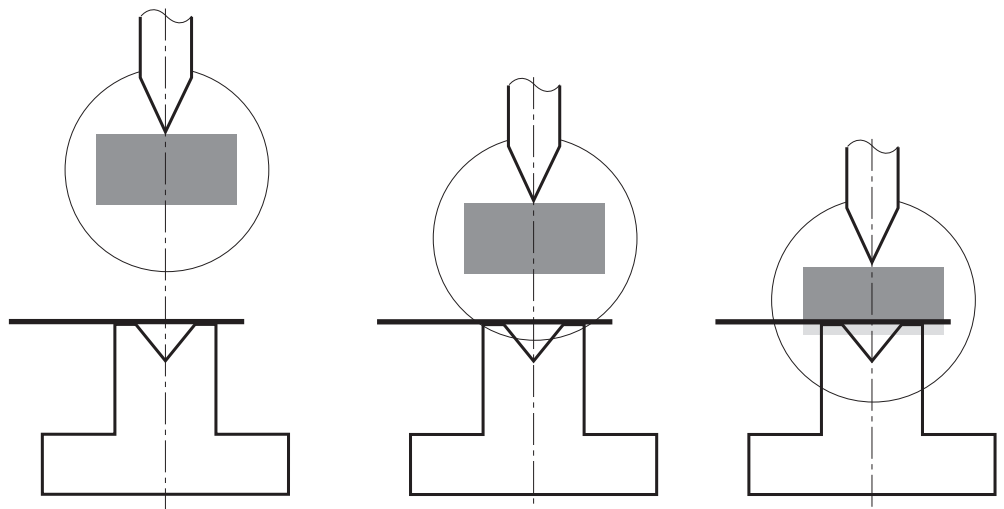

- Step ④** The calculation of the switch-over point includes an additional 6 mm safety gap required to reach the target speed (v_{slow}). The protective volume becomes inactive.
- Step ⑤** The die contacts the workpiece (pinch point).
- Step ⑥** The die shapes the workpiece. The operating cycle ends at the programmed bottom dead centre. The die goes back up.

Protective volume

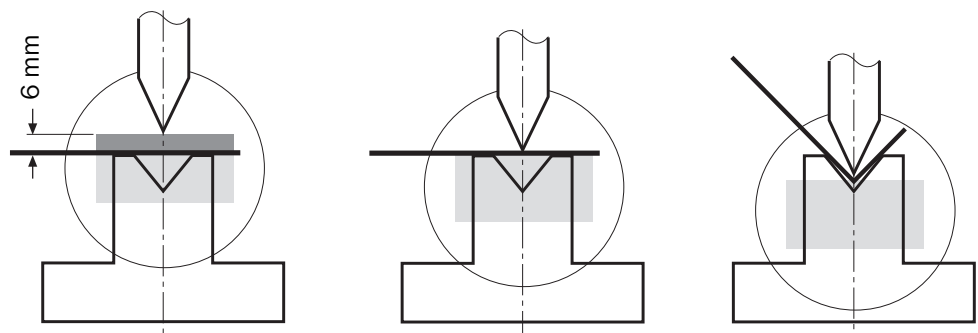

3.2.3 Intrusion of the protective volume during the operating cycle

This sequence shows how the V 4000 PB responds when there is an interruption to the protective volume.

- Step ①** The die is at the programmed top dead centre. There is a foreign object on the workpiece or female die. The operator gives the signal to start the closing movement (foot switch).
- Step ②** The die descends at high speed (> 10 mm/s). The entire protective volume is active.
- Step ③** Part of the protective volume is interrupted by the object. The OSSDs go into the OFF state and generate a safe stop signal. The press controller must ensure the stop procedure is implemented.

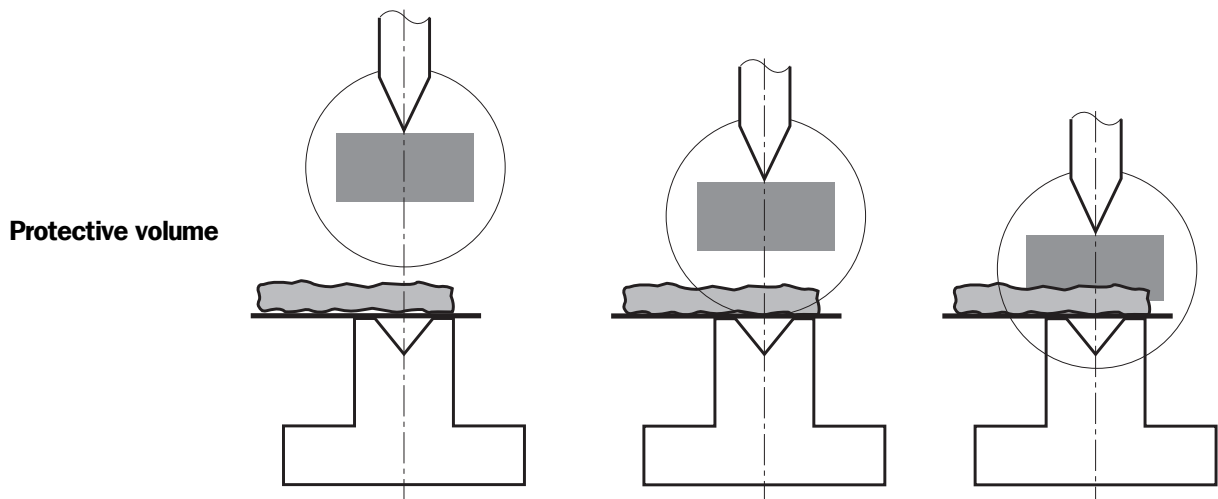

- Step ④** The die continues to move in accordance with the overall machine overrun and stops at least 5 mm above the object.
- Step ⑤** The object is now removed. The protective volume is clear again.
- Step ⑥** The operator gives the signal once more to start the closing movement (foot switch). The closing movement starts and the operating cycle resumes.

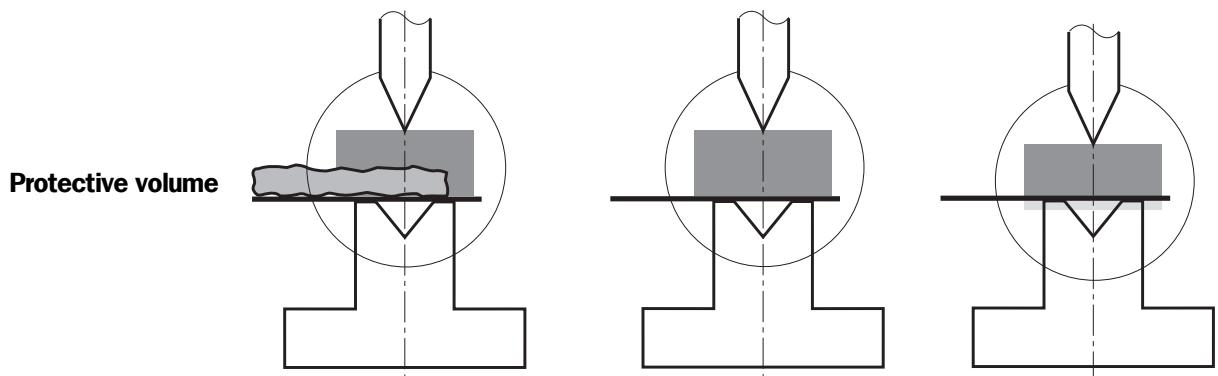

3.3 Range of use

The V 4000 PB is an ESPE (electro-sensitive protective equipment) device designed to protect the area beneath the die of press brakes at high closing speeds, it provides hand and fingers protection.

The V 4000 PB is suitable for stationary use in press brakes with a maximum distance of 7.5 m between the sender and the receiver.

The press brake must be designed to comply with the maximum stopping distance of 11 m.

This corresponds, for example, to a maximum overall machine overrun of 8.5 mm at a maximum closing speed of 250 mm/s (see also Section 3.5.13 "Maximum closing speed and maximum overall machine overrun").

Requirements for use of the V 4000 PB

Before the V 4000 PB can carry out its protective functions the following conditions must be met:

- It must be possible to influence the control of the press brake by electrical means.
- The OSSDs of the V 4000 PB must be incorporated into the press controller in such a way that when the OSSDs give the switch-off signal:
 - the dangerous state (high closing speed of > 10 mm/s) is stopped.or
 - the press, should the lock-out state occur, does not start up again.
- The V 4000 PB must be mounted and configured in such a way that it can detect objects when they penetrate into the hazardous point.

3.4 Structure of the device

The V 4000 PB comprises the following components:

- Sender
- Receiver with interfaces
- PBI with interfaces
- CDS (software for configuration and diagnostics of the V 4000 PB sensor)

In addition the V 4000 PB needs control signals from *external operating elements*.

The sections which follow describe the individual components of the device.

Fig. 8: Components

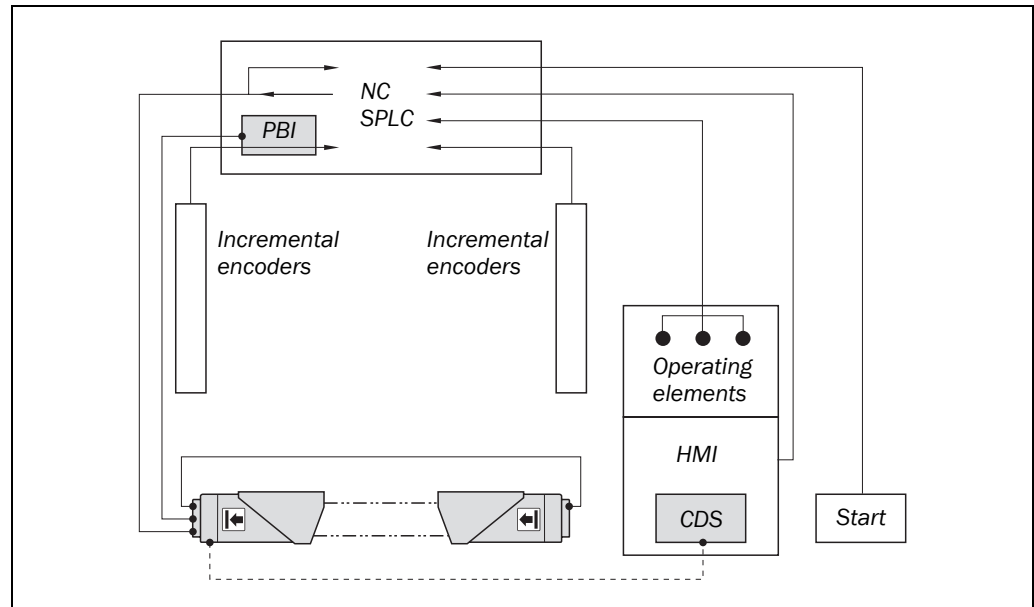

3.4.1 Sender and receiver

Fig. 9: Sender and receiver

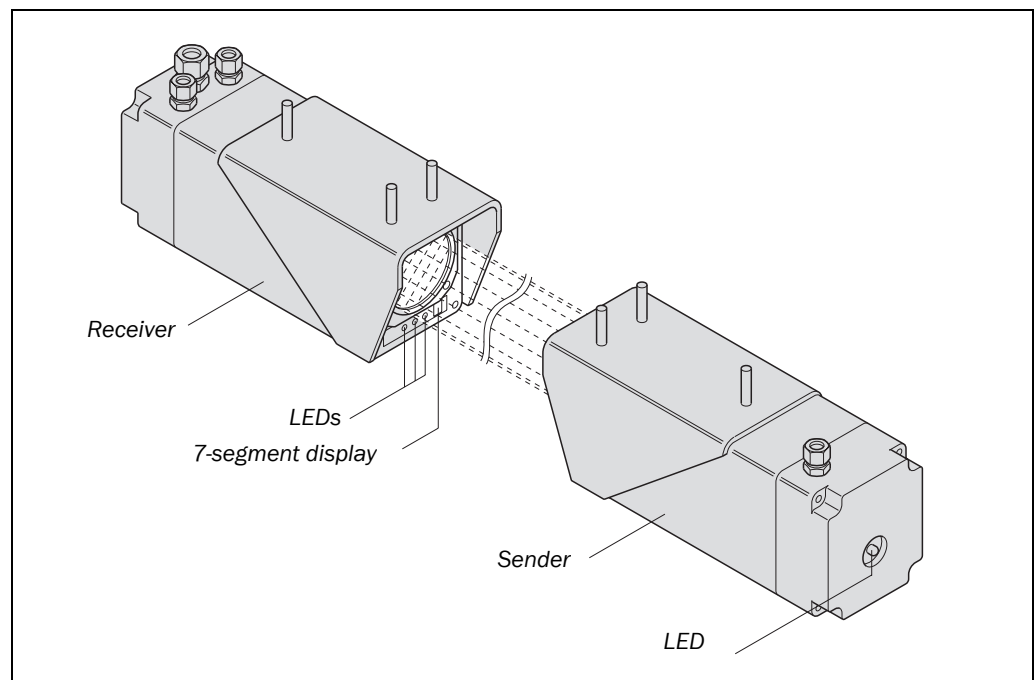

Sender and receiver are mounted on the press crosshead and follow the movements of the crosshead. At start-up and every time there is a change of tooling, they need to be precisely aligned to the length of the die used and to each other.

V 4000 PB

The laser diode in the sender emits light which is collected at the transmitting lens and given parallel alignment. The beam of light, which has a constant diameter of 58 mm (illumination field), travels along the lower side of the die to the receiver. In the receiver the light beam is mapped at the image detector.

The evaluation electronics with all relevant inputs and outputs is built into the receiver. Two output switching elements (OSSDs), which go into the OFF state when the sensor function is triggered, pass on the signal for stopping the closing movement (high closing speed > 10 mm/s).

3.4.2 Displays at the sender and receiver

Display at the sender

Fig. 10: Display at the sender

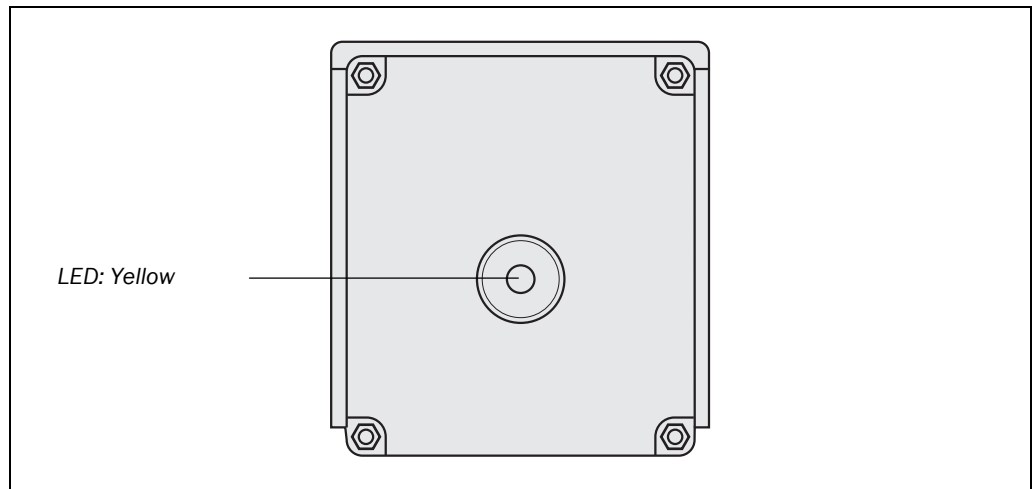

An LED on the sender displays the status.

Tab. 2: Display at the sender

Display	Meaning
● Yellow	Power supply OK. The sender of the V 4000 PB is switched on.

Displays at the receiver

The status of the V 4000 PB is displayed at the receiver via three LEDs and a 7-segment display.

Fig. 11: Displays at the receiver

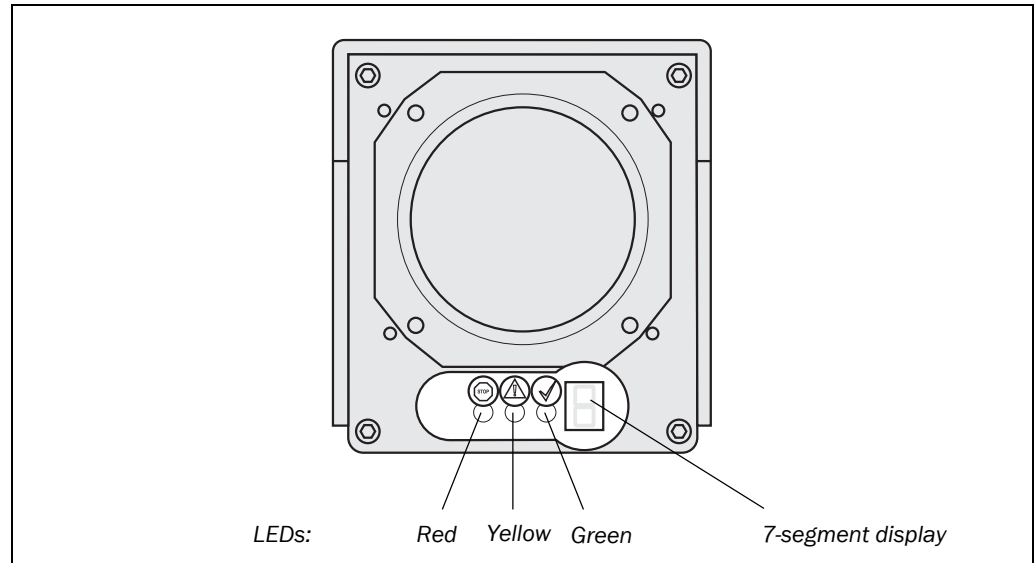

The LEDs tell the operator whether an input is expected and whether the OSSDs are in the OFF or ON state.

The 7-segment display provides the operator with further information about the status of the V 4000 PB.

Tab. 3: Key to the LEDs on the receiver display

Display	Meaning
☉ Yellow (10/90) (90/10)	<ul style="list-style-type: none"> Operator action (input) is required (On % / Off % at 1 Hz) <ul style="list-style-type: none"> – Alignment mode – Teach-in request
● Yellow	<ul style="list-style-type: none"> In production operation: Operator action (input) required <ul style="list-style-type: none"> – In standard mode (release foot switch) – In back-stop mode (first operation of the foot switch expected) – In box mode (first operation of the foot switch expected) During configuration: CDS connected and Configuration operating mode selected
● Red	<ul style="list-style-type: none"> System sending signals to switch off the machine (OSSDs in the OFF state) Additional states in which the red LED is illuminated: <ul style="list-style-type: none"> – Self-test (system initialisation) – Configuration – Box mode – Back-stop mode – Lock-out state – Alignment mode
● Green	System free (OSSDs in the ON state)

V 4000 PB

Tab. 4: Key to the 7-segment display on the receiver

Display	Meaning
	System error. The device is defective. Replace the receiver.
	Muting state
	Switch on. This is followed by self-testing of the V 4000 PB (system initialisation).
	Standard mode
	Box mode
	Back-stop mode
Other displays	All of the other displays are error messages, displays within alignment mode or displays during the self-test (system initialisation).

Note Further explanations of the 7-segment display will be found in the following sections:

- Displays during system initialisation when the machine is switched on (see Section 8.1 "Switching the machine on")
- Displays within alignment mode (see Section 7.2 "Aligning sender and receiver")
- Error displays within lock-out state (see Section 9.2 "Error displays of the LEDs")

3.4.3 Interfaces at the receiver

The receiver of the V 4000 PB has the following interfaces:

- Digital interface
- Serial interfaces for configuration and diagnostics
- Interface for connecting the sender
- Interface for connecting the PBI

Digital interface

The digital interface receives signals from the press controller or from external operating elements and passes them on to the receiver; it also passes signals from the receiver on to the press controller.

Tab. 5: Inputs and outputs at the digital interface

Number	Inputs and outputs with safety relevance	Function
2	Actively tested semiconductor switching outputs (OSSDs)	For the switch-off signal to the press controller which must stop the closing movement of the press crosshead with the die
2	Inputs	For the gated signal for starting the closing movement
Number	Standard inputs and outputs	Function
2	Pulsed outputs	For the bypass signal
2	Inputs	For the bypass signal
1	Input	For external device monitoring (EDM)
1	Output	For the target speed request to the press controller
1	Input	For activating alignment mode
1	Input	For activating teach-in mode
3	Inputs	For selecting the protective volume mode (standard, box, back-stop) within protective operation
1	Output	For the signal to the press controller that teach-in is being requested

Serial interface for configuration and diagnosis

The PC is connected to the receiver via the serial RS-232 interface for configuration of the V 4000 PB and for extended diagnostics with the SICK CDS Software in the event of servicing. For a permanent connection of the PC (CDS) to the receiver an RS-422 interface is available for extended diagnostics. A switch allows you to switch between the two interfaces (see Section 6.1 "Delivery state").

Interface for connecting the sender

To allow control of the sender function by the receiver, the sender and the receiver are electronically connected to the receiver via a signal line.

Interfaces for connecting the PBI

The receiver is provided with an interface for data transmission (incremental pulses of the measurement guide) from the PBI.

V 4000 PB

3.4.4 PBI (press brake interface)

Fig. 12: PBI (press brake interface)

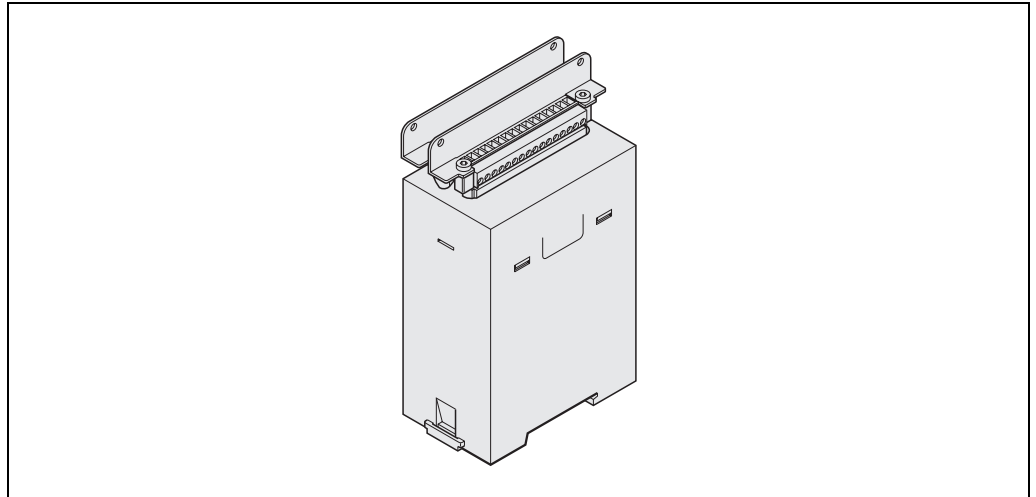

The incremental measurement guides of the press controller register the movement of the press crosshead. The speed and direction of movement of the press crosshead and the overall machine overrun are calculated by the V 4000 PB from the signals of one measurement guide and from other measured data (such as time).

The measurement guide is connected to the V 4000 PB via the PBI in the control cabinet. At the interface with the press controller the PBI taps onto the signals of the measurement guide, decouples them and passes them on to the receiver.

Position detection must be checked to ensure it is working properly. The V 4000 PB monitors whether the signals (increments) from the measurement guide have a logical order – in other words, whether they can be interpreted unambiguously as upward or downward movement or standstill.

Example

If a start signal for the closing movement is detected by the safety-relevant inputs, it will be assumed that the press brake is moving after a period of delay (start-up delay). If there is no movement – in other words, the signals from the PBI cannot be unambiguously interpreted as movement – the V 4000 PB assumes that there is a fault in position detection, switches the OSSDs into the OFF state, and goes into lock-out state.

The system will not change into the muting state unless the measurement system is delivering correct information which agrees with the expected values.

Display at the PBI

Fig. 13: Display at the PBI

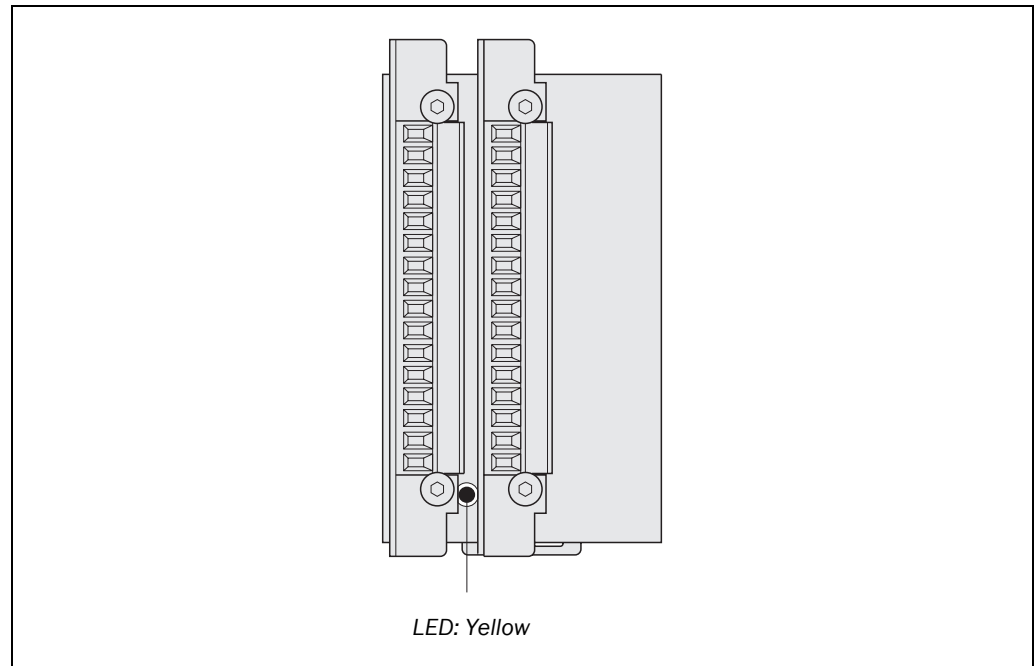

Tab. 6: Display at the PBI

Display	Meaning
● Yellow	Power supply OK.

Interface at the PBI

The PBI of the V 4000 PB has been designed for two-channel, incremental, linear measurement guides with an RS-422 interface. All signals of the measurement guide are looped through.

3.4.5 CDS (Configuration & Diagnostics Software)

The V 4000 PB is configured and diagnosed with the CDS software (Configuration & Diagnostics Software) running on Windows 98 and later operating systems.

Note For more information see the Sections 3.5 "Possible device configurations" and 9.4 "Extended diagnostics via CDS".

V 4000 PB

System configuration: version A

In the case of press brakes with PC control and a Windows user interface, the CDS for configuration or diagnostics of the V 4000 PB can be integrated into the control system.

Note Permanent – on-line - diagnostics and operation must be implemented solely via the RS-422 interface.

Fig. 14: System configuration with PC control

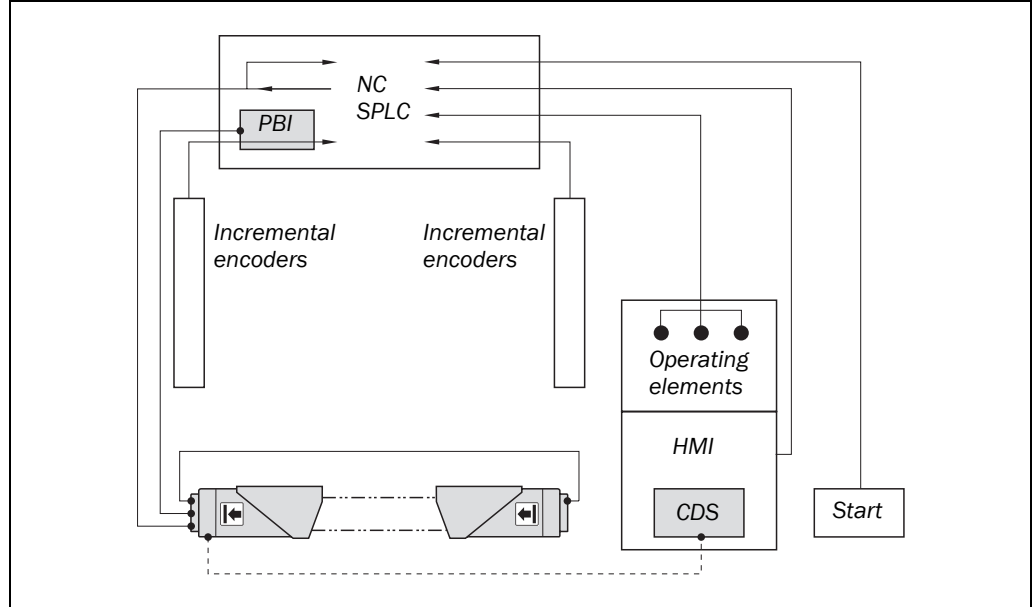

System configuration: version B

In the case of press brakes without PC control or a Windows user interface, the CDS for configuring the V 4000 PB must be connected to the receiver. A permanent connection with the CDS is not necessary.

Fig. 15: System configuration without PC control

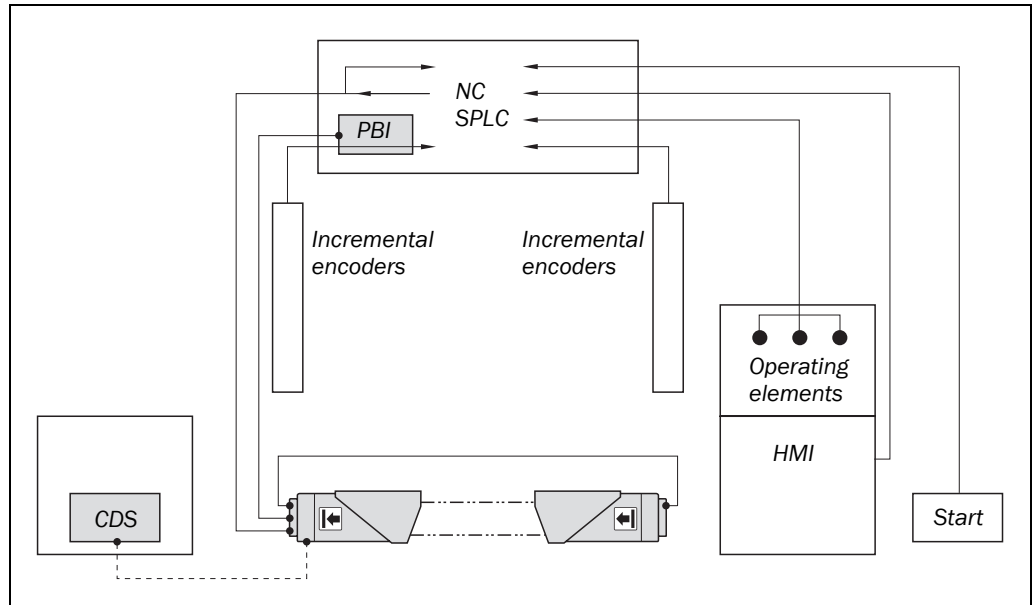

3.4.6 External operating elements

For controlling the V 4000 PB external signals are required. The V 4000 PB has the corresponding signal inputs for:

- Starting the closing or opening movements of the press brake
- Requesting alignment mode
- Requesting or confirming teach-in
- Selecting the protective volume mode (standard, box, back-stop)
- Requesting bypass mode

The signals are generated either by operating elements such as buttons or selector switches or by the outputs of the press controller.

Note How these various possibilities are actually implemented (for example, foot switch, alignment button, teach-in button, selector switch and key-operated switch, or corresponding switching elements on the MMI of the press controller) falls within the area of responsibility of the user.

Recommendation All switching elements should be large and sturdy. It must be possible to operate them reliably and simply while wearing gloves.

3.5 Possible device configurations

This section describes the parameters and functions of the V 4000 PB which can be configured via CDS.



WARNING

Check the V 4000 PB after making changes!

After making any change to the configuration you must check the effectiveness of the V 4000 PB (alignment, function and configuration data).

When starting to configure the V 4000 PB, you may save the configuration using an application name with a maximum of 22 characters. You should use unique designations with an evident relation to the concrete application name – such as "Machine name XYZ".



V 4000 PB device symbol, context menu **Configuration draft, Edit, Basic settings** tab

V 4000 PB

Tab. 7: Configurable parameters and functions

Basic settings	Description in Section
Source of the operator signals	3.5.1
Baud rate of communication interface	3.5.2
Application name	3.5.3
Repetition interval of power-up cycle	3.5.4
Mounting of receiver	3.5.5
Position-sensing system Increments per mm stroke Measurement direction during closing movement	3.5.7
Speed-dependent muting	3.5.6
External device monitoring	3.5.8
Standstill time for determining the top dead centre	3.5.15
Start delay for closing movement	3.5.16
Time for standstill detection	3.5.17
Braking distance	
Default value for braking distance	3.5.9
Travel for determining braking distance	3.5.10
Braking offset	3.5.11
Target speed v_{slow}	3.5.12
Overall machine overrun	
Max. overall machine overrun	3.5.13
Travel for determining overall machine overrun	3.5.14
Maximum closing speed	3.5.13
Inputs	
Settling times for standard inputs	3.5.18
Settling times for safety-relevant inputs	
Discrepancy time for safety-relevant inputs	3.5.19
Discrepancy time for protective volume selection	
Maximum duration of 1st operation (confirmation of reduced protective volume)	3.5.20
Start signal Time for pause between 1st and 2nd operation	
Outputs	
Minimum state time for standard inputs	3.5.21
Minimum switch-off time of safety-relevant outputs	3.5.22
Bypass	
Bypass	3.5.23
Discrepancy time for bypass inputs	3.5.19

3.5.1 Source of the operator signals

With the CDS the V 4000 PB can be configured to accept operator signals (alignment, teach-in, reset, and selection of the protective mode) either from the CDS software or from external touch elements such as buttons or selector switches. Use of CDS to provide these operator signals requires a dedicated permanent (on-line) communication interface between the V 4000 PB and CDS via a RS-232 port.

Another method for providing operator signals to the V 4000 PB is via the HMI of the numerical control. These signals could be collected via touch buttons connected to the NC interface or via software buttons on the HMI console.

Note Signals of the operating elements of the CDS overwrite signals of the external operating elements. There could be inconsistencies between the system state and the state of the V 4000 PB.



V 4000 PB device symbol, context menu **Configuration draft, Edit, Basic settings** tab

3.5.2 Baud rate communication interface

By means of the CDS the baud rate (transmission rate) can be set at the serial interface for configuration (between V 4000 PB and connected PC). The setting will depend on how powerful the PC is.



V 4000 PB device symbol, context menu **Configuration draft, Edit, Basic settings** tab

3.5.3 Application name

When starting to configure the V 4000 PB, you may save an application name with a maximum of 22 characters.

Here you should use unique designations with an evident relation to the concrete application name – such as "Machine name XYZ".



V 4000 PB device symbol, context menu **Configuration draft, Edit, Basic settings** tab

3.5.4 Repetition interval of power-up cycle

The V 4000 PB has an internal time monitor for certain functions. The time monitor should ensure a regular check is made in the case of uninterrupted operation. The start times are saved and compared with the current state. If the time for a particular function has elapsed, a corresponding operator action will be requested.

Following an interruption to the supply voltage all times will be reset to zero.

The V 4000 PB monitors the time since the last power-up cycle and requests a new power-up cycle if the configured value (≤ 24 h) is exceeded.



V 4000 PB device symbol, context menu **Configuration draft, Edit, Basic settings** tab

3.5.5 Mounting of receiver

In back-stop mode, the active protective volume segment as seen from the operator side is behind the pressure axis.

In order to place the active protective volume correctly, it is necessary to specify during configuration on which side of the press brake (as seen from the operator side) the receiver is mounted.



V 4000 PB device symbol, context menu **Configuration draft, Edit, Basic settings** tab

3.5.6 Speed-dependent muting

Any one of the following conditions will result in automatic muting of the V 4000 PB (inactivation of the protective volume):

- Gap size ≤ 6 mm above the taught-in pinch point
- Upward movement

In addition a closing movement at a low closing speed v_{craw1} (≤ 10 mm/s) will also cause the system to go automatically into muting mode provided this option has been enabled during configuration.

The closing speed is continually monitored. If the slow closing speed v_{craw1} is exceeded in the muting state, muting will be deactivated and the protective volume activated.

With automatic muting at the slow closing speed v_{craw1} it is possible for the press brake to close at slow closing speed despite an interruption of the protective volume.

If slow closing speed v_{craw1} has not yet been reached when the protective volume is interrupted, the press will be stopped. After this the press brake can be closed at slow closing speed via the press controller and a new start signal.

If slow closing speed has already been reached when the protective volume is interrupted, a new start signal will not be needed.

Note If a slow closing speed (≤ 10 mm/s) is permitted by the applicable regulations as the sole protective measure, the option may be activated by the machine setter. In ANSI standard B11.3 "Safety Requirements for Power Press Brakes" the slow closing speed (≤ 10 mm/s) is not specified as the sole protective measure!



V 4000 PB device symbol, context menu **Configuration draft, Edit, Basic settings** tab

3.5.7 Position-sensing system

The measurement guides (incremental encoders) of the press controller register the position of the press crosshead.

Increments per mm stroke

The V 4000 PB requires the resolution of the incremental encoder [INC/mm] in order to calculate the speed and direction of movement of the press crosshead and the overall machine overrun from the signals of one measurement guide and from other measured data (such as time).

The incremental encoder must support two channels with at least 45 INC/mm and a maximum of 300 INC/mm at a closing speed of 250 mm/s. The recommendation is 50 INC/mm.

Measurement direction during closing movement

The 0° and the 90° signal of the incremental encoder are phase-shifted. During a closing movement (positive sign) the V 4000 PB expects the 0° signal to be leading.

Fig. 16: Incremental encoder signals

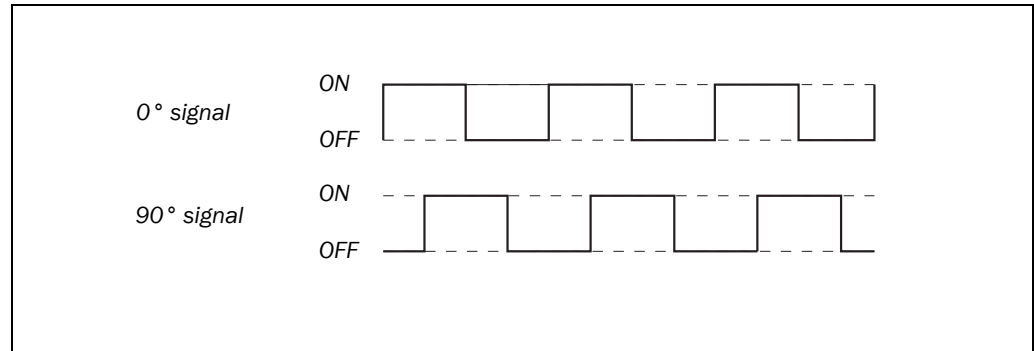

Note When connecting the incremental encoder channels, make sure that they do not swapped or interchanged as this would lead to the direction of movement being misinterpreted. If a measurement guide is replaced, you will need to check the configuration and input the resolution of the new measurement guide into the configuration.



V 4000 PB device symbol, context menu **Configuration draft, Edit, Basic settings** tab

3.5.8 External device monitoring (EDM)

The EDM checks if the contacts actually de-energise when the protective device responds. If an external device monitor is present, external device monitoring must be activated in the CDS. The V 4000 PB will then check the contacts every time the protective volume is interrupted and before the press brake restarts.

The external device monitor can tell whether a contact is welded or whether a contact/relay has not de-energised due to a different mechanical fault. If, due to the failure of a contactor, the system cannot go into a safe operating state the OSSDs will go into the OFF state, the V 4000 PB changes to lock-out state and a reset becomes necessary.



V 4000 PB device symbol, context menu **Configuration draft, Edit, Basic settings** tab

3.5.9 Default value for braking distance

During the power-up cycle, the braking distance (transition from the high closing speed to the target speed v_{slow}) is also determined.

From the braking distance and the pinch point (which was determined during teach-in) the positions for the switch-over and muting points are calculated.

The CDS includes a default value of 30 mm for the braking distance which may not, under any circumstances, be exceeded by the measured braking distance.



V 4000 PB device symbol, context menu **Configuration draft, Edit, Braking distance** tab

3.5.10 Travel for determining the braking distance

During the power-up cycle, the braking distance (transition from the high closing speed to the target speed v_{slow}) is also determined. The travel for determining the braking distance is the distance the press requires to accelerate to the high closing speed and then brake down again to the target speed v_{slow} .

The CDS includes a set value of 30 mm for the travel for determining the braking distance.



V 4000 PB device symbol, context menu **Configuration draft, Edit, Braking distance** tab

3.5.11 Braking offset

During braking to the target speed v_{slow} , vibrations in the V 4000 PB and braking distance fluctuations may occur.

The design of the V 4000 PB specifies that the vibration tolerance of the V 4000 PB for gap sizes from 6 mm to 26 mm increases from ± 4 mm to ± 7 mm.

With the braking offset the gap size at which the target speed v_{slow} is reached is increased.

Tab. 8: Braking offset

Braking offset	Gap at v_{slow}	Availability with braking distance fluctuations	Remark
6 mm	6 mm	± 4 mm	Maximum productivity
26 mm	26 mm	± 7 mm	Maximum availability

The braking offset is added to the braking distance calculated from the power-up cycle:

- With a braking offset of 6 mm the target speed v_{slow} is reached at the muting point (6 mm above the pinch point).
- If a braking offset of more than 6 mm is selected, the switch-over point will be shifted upwards.

The V 4000 PB requests the target speed v_{slow} before the calculated switch-over point.

The press brakes earlier and thus reaches the target speed v_{slow} before the muting point.



V 4000 PB device symbol, context menu **Configuration draft, Edit, Braking distance** tab

3.5.12 Target speed v_{slow} for determining the braking distance

In the determination of the braking distance, the target speed v_{slow} is the speed which the press must reach after the braking procedure.

The CDS specifies a set value of 10 mm/s for the target speed.



V 4000 PB device symbol, context menu **Configuration draft, Edit, Braking distance** tab

3.5.13 Maximum closing speed and maximum overall machine overrun

Maximum closing speed

The following values are defined for the closing speed:

- v_{\max} = maximum closing speed (depends on machine design), held in the configuration
- v_p = high closing speed which is reached in the current operating cycle and is measured by the V 4000 PB

During configuration the maximum closing speed of the press is input as the maximum closing speed v_{\max} . This speed must not be exceeded in any operating cycle.

The press crosshead travels at high closing speed (>10 mm/s) up to the switch-over point. The high closing speed v_p is continually monitored.

Should the press brake exceed the high closing speed of the last power-up cycle a new power-up cycle will be needed. During the power-up cycle, the high closing speed v_p and the overall machine overrun D (as a function of the high closing speed) are determined. The high closing speed must be less than or equal to the configured maximum closing speed.

Note The configured maximum closing speed in combination with the configured maximum overall machine overrun must not exceed the stopping distance of the V 4000 PB and will therefore need to be checked during configuration.



V 4000 PB device symbol, context menu **Configuration draft, Edit, Overall machine overrun** tab

Maximum overall machine overrun

The following values are defined for the overall machine overrun:

- D_{\max} = maximum overall machine overrun (depends on machine design), held in the configuration
- D = overall machine overrun which is reached with the current emergency stop and is measured by the V 4000 PB

During configuration the maximum overall machine overrun of the press is input as the maximum overall machine overrun D_{\max} . This overall machine overrun must not be exceeded in any emergency stop.

During the closing movement of the press, and after an emergency stop, the press brake will continue to run for a distance (overall machine overrun D) which is less than the maximum machine overrun D_{\max} .

If the distance exceed the maximum machine overrun, D_{\max} , the V 4000 PB will require a new power-up cycle.

During the power-up cycle, the high closing speed v_p and the overall machine overrun D (as a function of the high closing speed) are determined.

At every emergency stop the overall machine overrun is measured. Should the overall machine overrun measured exceed the value of the overall machine overrun of the last power-up cycle the V 4000 PB will switch into its lock-out state.

To cancel the lock-out state, a reset and a new power-up cycle are necessary. The overall machine overrun is determined and at the next emergency stop is available as a well-founded value for the overall machine overrun.

Note The configured maximum overall machine overrun in combination with the configured maximum closing speed must not exceed the stopping distance of the V 4000 PB and will therefore need to be checked during configuration.



V 4000 PB device symbol, context menu **Configuration draft, Edit, Overall machine overrun** tab

Stopping distance

The stopping distance is a system parameter from the V 4000 PB and the press brake which is defined in the design of the V 4000 PB.

The stopping distance S describes the maximum path distance that the press brake covers in the time between the sensor function activation and the press being at a standstill.

The following condition applies: $S = T_1 * v_{max} + D_{max}$

$$S \leq 11 \text{ mm}$$

The response time T_1 of the V 4000 PB is constant. The parameters maximum overall machine overrun D_{max} and maximum high closing speed v_{max} can be adjusted with regard to the stopping distance.

A press brake with a large overall machine overrun can be equipped with the V 4000 PB if its maximum closing speed is limited by making modifications to the hydraulics system (such as orifice plates). A very high closing speed is only possible when combined with a short overall machine overrun.

Note The maximum overall machine overrun and the maximum closing speed must be configured during installation so that they satisfy the condition of the stopping distance.

3.5.14 Travel for determining the overall machine overrun

During the power-up cycle, the overall machine overrun following an emergency stop (transition from the high closing speed to standstill) is also determined. The travel for determining the overall machine overrun is the distance the press requires to accelerate to the high closing speed.

The CDS includes a default value of 30 mm for the maximum travel for determining the overall machine overrun.



V 4000 PB device symbol, context menu **Configuration draft, Edit, Overall machine overrun** tab

3.5.15 Standstill time for determining the top dead centre

The V 4000 PB recognises when the opening movement of the press has ended in the operating cycle – in other words, when the top dead centre has been reached.

Should the press crosshead make no further upward movement for a specific, configured period of time (standstill time), the V 4000 PB will assume that the top dead centre has been reached.

Note Detection of the top dead centres is only necessary during the power-up cycle. The top dead centre is not monitored and not reaching it is permitted during production operation.



V 4000 PB device symbol, context menu **Configuration draft, Edit, Basic settings** tab

3.5.16 Start delay for closing movement

If a start signal for the closing movement is detected by the safety-relevant inputs, it will be assumed that the press brake is moving after a period of delay. If there is no movement – in other words, the signals from the PBI cannot be unambiguously interpreted as movement – the V 4000 PB assumes that there is a fault in position detection.

The time delay between the start signal to the V 4000 PB for the closing movement and the actual movement of the press brake depends on the switching times of the individual components of the press.



V 4000 PB device symbol, context menu **Configuration draft, Edit, Basic settings** tab

3.5.17 Time for standstill detection

The V 4000 PB detects when the press is at a standstill.

Should the press crosshead make no further change in position for a specific, configured period of time (standstill time), the V 4000 PB will assume that the press is at a standstill.



V 4000 PB device symbol, context menu **Configuration draft, Edit, Basic settings** tab

3.5.18 Settling times for inputs

When a switch is switched on or off, there will be an undefined state for a brief period. The signal goes back and forth between the ON and OFF states until a defined state is reached.

Fig. 17: Settling times

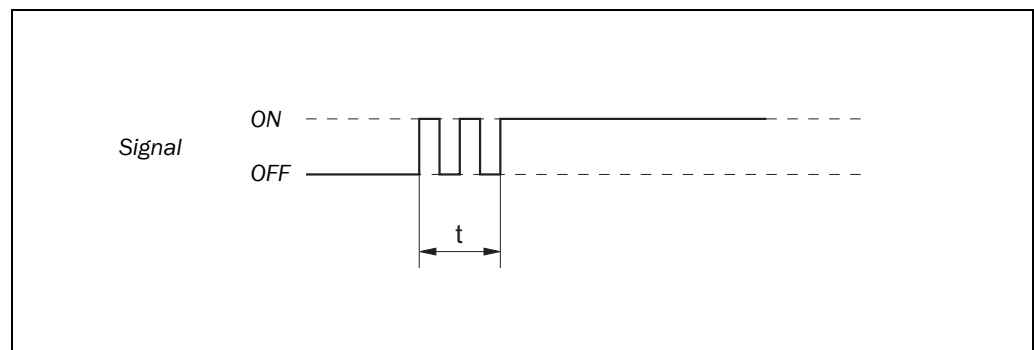

An undefined state will result in an error following logic checking by the V 4000 PB and will thus initiate the lock-out state.

To prevent this from happening, a time period (the settling time) is configured via the CDS for which the V 4000 PB will ignore the undefined state.

Settling times can be configured for the following inputs and outputs:

- Standard inputs
- Safety-relevant inputs



V 4000 PB device symbol, context menu **Configuration draft, Edit, Inputs** tab

3.5.19 Discrepancy times for inputs

Two-channel inputs supply two complementary signals. Here the switching-off operation has ended somewhat earlier than the switching-on operation. This results for a brief period in an undefined state.

Fig. 18: Discrepancy times

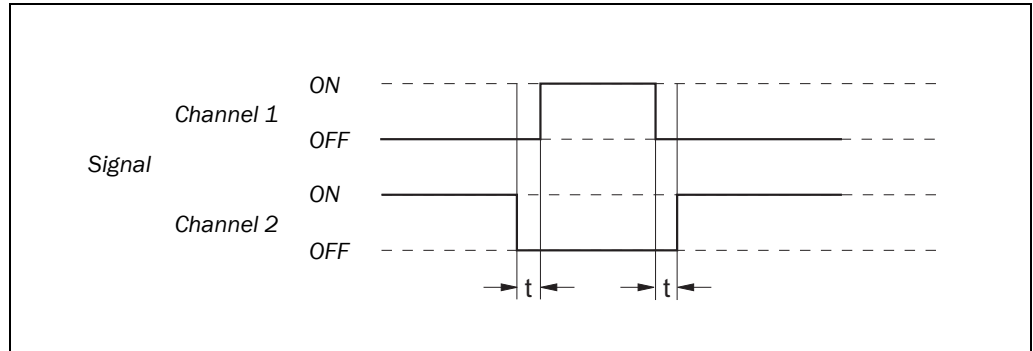

An undefined state will result in an error following logic checking by the V 4000 PB and will thus initiate the lock-out state.

To prevent this from happening, a time period (the discrepancy time) is configured via the CDS for which the V 4000 PB will ignore the undefined state.

Discrepancy times can be configured for the following inputs and outputs:

- Safety-relevant inputs
- Inputs for selecting the protective volume mode
- Bypass input



V 4000 PB device symbol, context menu **Configuration draft, Edit, Inputs** or **Bypass** tab

3.5.20 Start signal with reduced protective volume (double-click)

In the case of the box and back-stop protective volume modes, the start signal for the closing movement must be given twice. This is intended to draw the operator's attention to the fact that he is working in a special mode in which only limited protection is provided by the reduced protective volume.

Via the CDS you can configure the **maximum duration of the first start signal** (how long the operator must operate the corresponding operating element) and the **pause between the first and second start signal**.

Fig. 19: Start signal (double-click)

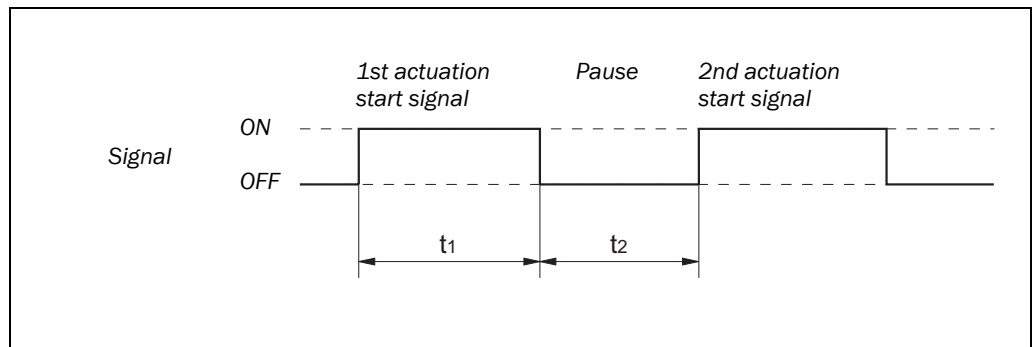

V 4000 PB device symbol, context menu **Configuration draft, Edit, Inputs** tab

3.5.21 Minimum state time for standard outputs

The time after which a digital output signal changes from the OFF to the ON state, or vice versa, can be configured via the CDS so that the signal can be registered by the systems connected to the V 4000 PB. The minimum configurable state time is 0 ms while the maximum configurable state time is 1000 ms.



V 4000 PB device symbol, context menu **Configuration draft, Edit, Outputs** tab

3.5.22 Minimum switch-off time for safety-relevant outputs

The time for which the signal of the OSSD outputs remains at minimum in the OFF state (after an interruption of the protective volume, for example), can be configured via the CDS so that the signal can be registered by the systems connected to the V 4000 PB.

The minimum configurable switch-off time is 100 ms while the maximum configurable switch-off time is 1000 ms.



V 4000 PB device symbol, context menu **Configuration draft, Edit, Outputs** tab

3.5.23 Bypass

In bypass mode the press brake can be operated without the V 4000 PB protective device being activated.

To activate bypass mode, the bypass function is enabled in the configuration and the outputs of the bypass function at the receiver connected with its inputs.

In bypass mode the OSSDs are in the ON state and all displays on the receiver are switched off. The V 4000 PB does not generate any output signals (request for target speed, request for teach-in).

The bypass is deactivated by breaking the electrical connection between output and input. After the bypass mode is deactivated, the V 4000 PB changes to the restart interlock and requests a new power-up cycle.

Note The operator is responsible for the use and perfect functioning of additional safety devices which ensure the safe operation of the press brake (for example, the use of robots for handling materials).



V 4000 PB device symbol, context menu **Configuration draft, Edit, Bypass** tab

3.6 Protective operation

In protective operation the V 4000 PB safeguards the hazardous point beneath the die during the operating cycle at high closing speed (>10 mm/s).

Operating states within protective operation

The following operating states are available within protective operation:

- Power-up cycle
- Teach-in
- Production operation

The following is true for all operating states:

- The protective volume is active and is monitored for interruption.
- The position, direction of movement, speed and overall machine overrun are monitored and evaluated.

Protective volume modes in protective operation

Within protective operation there are also three protective volume modes available which make it possible to adjust the protective volume to best suit the current bending job:

- Standard mode
- Box mode
- Back-stop mode

3.6.1 Power-up cycle

In the power-up cycle the overall machine overrun at high closing speed and the braking distance (the transition from high closing speed to target speed) are determined for monitoring during press operation. Following this the teach-in procedure is carried out.

- During the power-up cycle the protective volume is active.
- The power-up cycle is requested by the V 4000 PB after every switch-on or reset of the V 4000 PB.
- At least once every 24 hours (in the case of continuous press operation) the V 4000 PB system automatically requests the power-up cycle.
- The operator confirms the power-up cycle by giving the teach-in signal via the press controller or external operating elements.

3.6.2 Teach-in

During teach-in the pinch point (which depends on the thickness of the material or the relative position of the top surface of the workpiece) is determined. The die contacts the workpiece at the pinch point. From the pinch point the positions for the switch-over and muting points are calculated.

- During teach-in the protective volume is active.
- The operator or the V 4000 PB system can request teach-in.
- The pinch point is monitored during each stroke of the press. The V 4000 PB detects when the position of the pinch point does not correspond to the value last determined. The system then requests teach-in which the operator must confirm via the controller or an external operating element.

Note V 4000 PB calculates from the pinch point all safety-relevant parameters (switch-over and muting points). For this reason, following a change of material the safety-relevant parameters will no longer apply.

This means that you will need to carry out the teach-in procedure every time the workpiece material changes.

3.6.3 Protective volume modes in protective operation

Standard mode

Standard mode is used when flat workpieces are to be bent and it is not expected that at high closing speed the protective volume will be interrupted by the shape of the workpiece. In standard mode the entire protective volume is monitored for interruption.

Fig. 20: Protective volume in standard mode

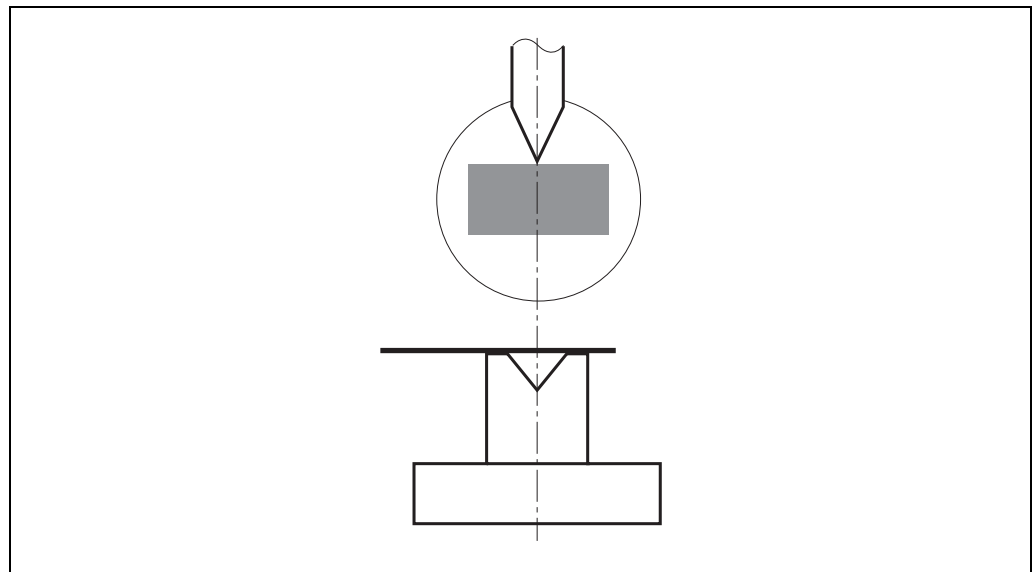

Box mode



WARNING

Catching or crushing of fingers or hands is possible due to the protective volume being partially blanked and also in the tolerance zone at the pressure axis!

The partial blanking of the protective volume means that objects within the tolerance zone will not be detected.

➤ Make sure that the workpiece is handled correctly (see Section 2.5 "Safety in operation").

Box mode is used when the workpiece needs to be bent several times (as when boxes or trays are being made, for example) and it is expected that at high closing speed the protective volume will be interrupted by the shape of the workpiece.

Fig. 21: Reduced protective volume in box mode

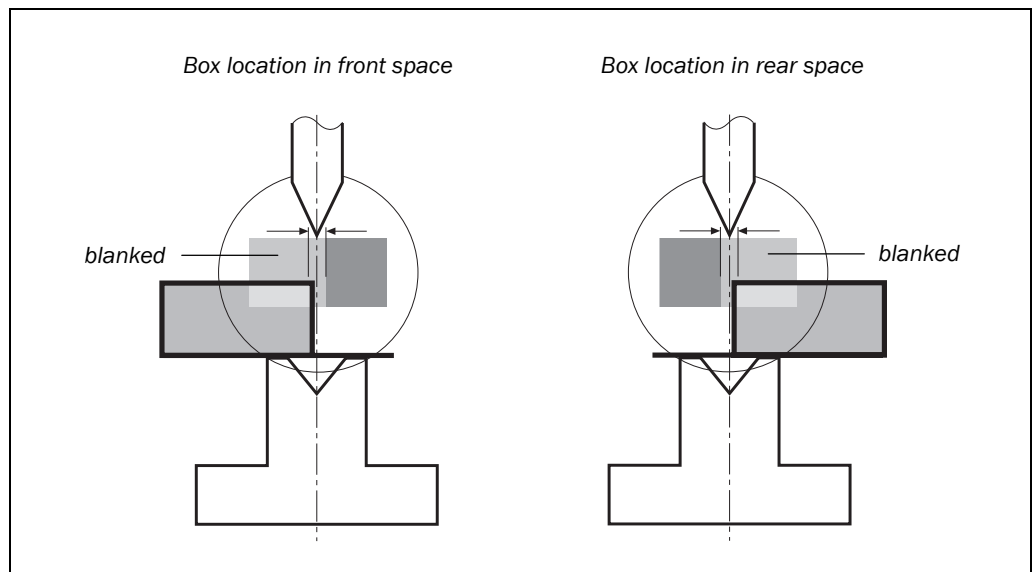

Note Box mode may be used in either of **two variants**:

Variant A

Up until the time when the protective volume is interrupted by the top of the box the entire protective volume is checked for interruption (as in standard mode).

In the case of the protective volume being interrupted from one side, either in front of or behind the pressure axis, this interruption will automatically be interpreted as the box wall. In box mode the corresponding segment of the protective volume and a tolerance zone (positioned centrally on the pressure axis) will be blanked automatically and the closing movement will not be stopped.

If the protective volume is interrupted in both segments (in front of and behind the pressure axis), this will initiate a stop signal which must stop the movement of the press crosshead.

Since in box-bending the side walls of the box can project behind the pressure axis, the tolerance zone at the pressure axis is blanked.

Variant B

The press brake is closed at high closing speed leaving but a gap. As in standard mode the entire protective volume is monitored. The operator stops the movement of the press crosshead.

The box is then slid into the gap. The corresponding segment of the protective volume is blanked automatically.

A new starting pulse finishes the operating cycle.

Recommendation

If possible use Variant B of box mode for bending boxes since the operating cycle is mostly carried out in standard mode.

Note

If the press brake is closed leaving a gap of ≤ 6 mm before the box is inserted into the gap, work can be carried out in standard mode.

Back-stop mode

WARNING

Catching or crushing of fingers or hands due to the protective volume being partially blanked and also in the tolerance zone at the pressure axis!

The partial blanking of the protective volume means that objects within the tolerance zone will not be detected.

➤ Make sure that the workpiece is handled correctly (see Section 2.5 "Safety in operation").

Back-stop mode is used during bending of very short legs or flanges when the rear stops have to be moved up very close to or even onto the female die with the result that the protective volume is interrupted by the rear stop at high closing speed.

Boxes can also be bent in back-stop mode.

In back-stop mode, the protective volume segment on the operator side is blanked completely and the part behind the pressure axis blanked partially.

The side on which the receiver is mounted is defined via the CDS and this ensures that the correct protective volume segment is blanked.

Fig. 22: Reduced protective volume in back-stop mode

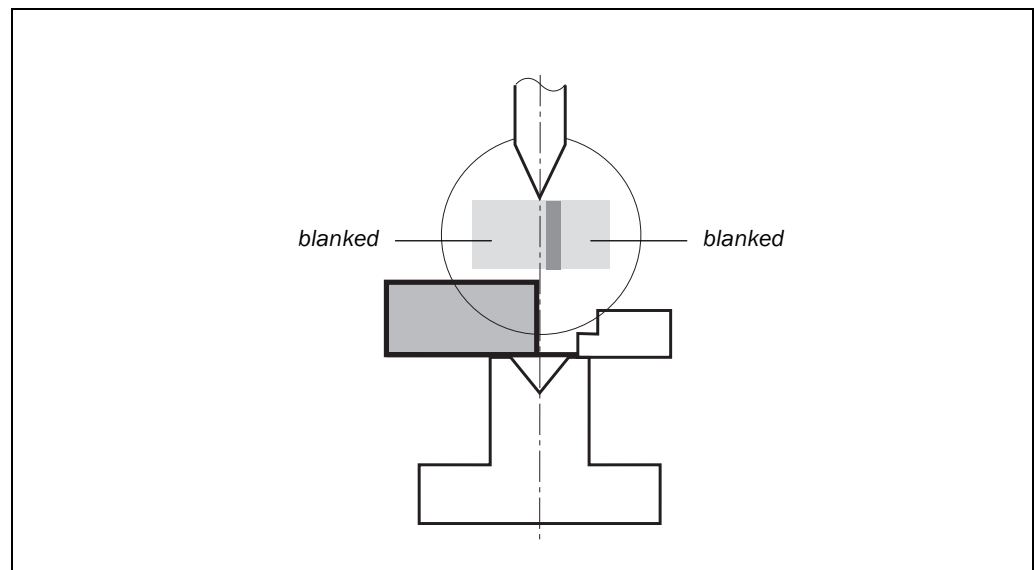

3.7.1 Power-up cycle in standard mode

Start condition: the system starts, carries out the self-test and waits for acknowledgement from the operator for the request signal for teach-in.

- Step**
- ① The die is at any point in the operating cycle. The operator gives the signal for teach-in (teach-in button).
 - ② The operator gives the signal to start the closing movement (foot switch). The die descends at maximum closing speed. v_p is measured.
 - ③ After about 20 mm the OSSDs go into the OFF state and generate a safe stop signal. The high closing speed must be stopped. The V 4000 PB determines the overall machine overrun.

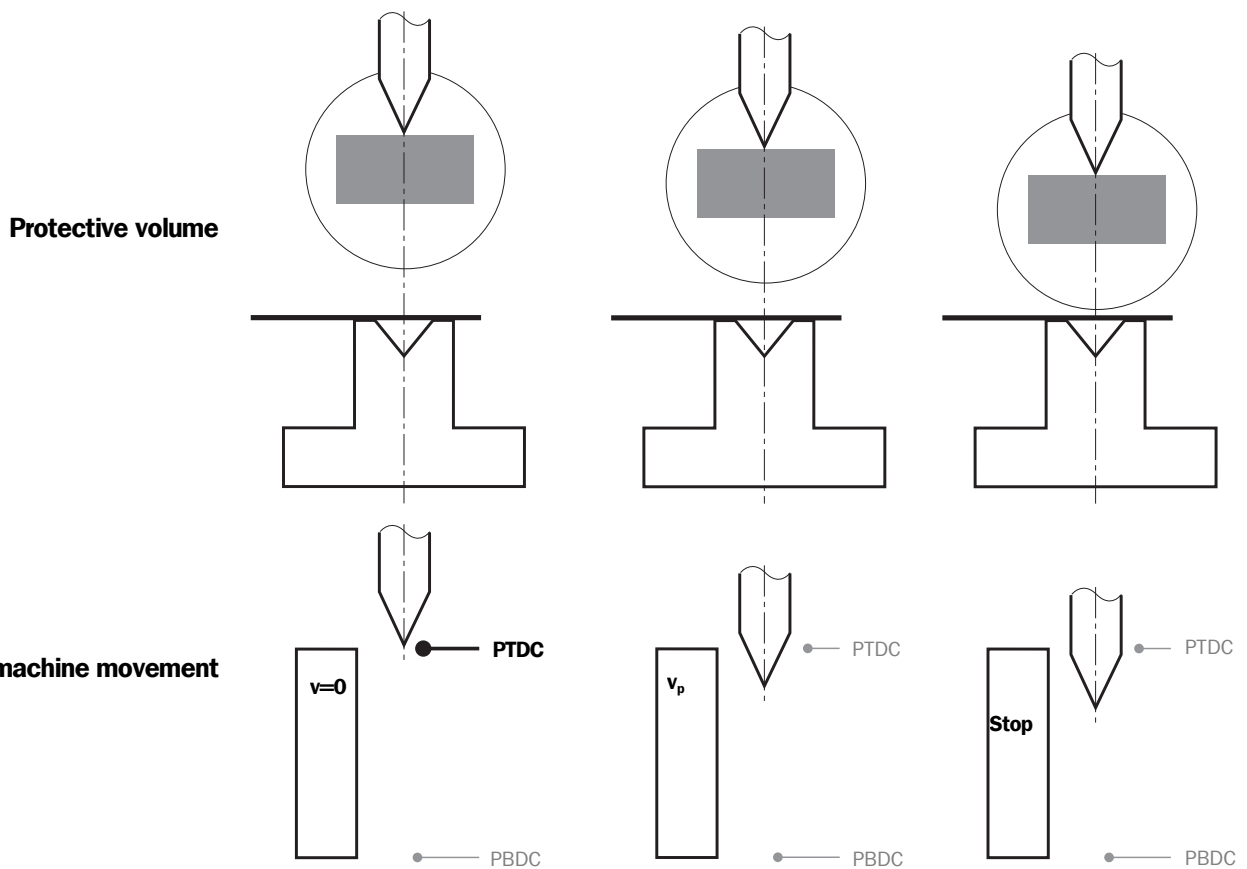

System state	● Red ⦿ Yellow ○ Green	○ Red ○ Yellow ● Green	● Red ○ Yellow ○ Green
7-segment display			
Start signal for closing movement	<input type="checkbox"/>	<input checked="" type="checkbox"/>	<input checked="" type="checkbox"/>
Request signal V_{slow}	<input type="checkbox"/>	<input type="checkbox"/>	<input type="checkbox"/>
OSSD	<input type="checkbox"/>	<input checked="" type="checkbox"/>	<input type="checkbox"/>
Request signal for teach-in	<input checked="" type="checkbox"/>	<input type="checkbox"/>	<input type="checkbox"/>

V 4000 PB

- Step ④** The overall machine overrun of the press brake is determined. The overall machine overrun must not exceed the configured value.
- Step ⑤** The operator gives the signal once more to start the closing movement (foot switch). The die descends at maximum closing speed v_p .
- Step ⑥** The target speed v_{slow} is requested by the V 4000 PB. The press controller starts the braking procedure. When v_{slow} is reached the braking distance is calculated.

Protective volume

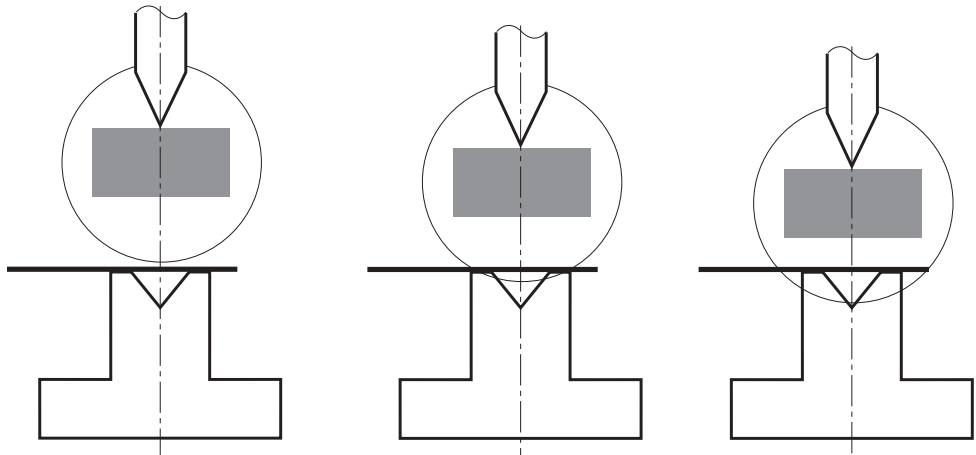

Speed; machine movement

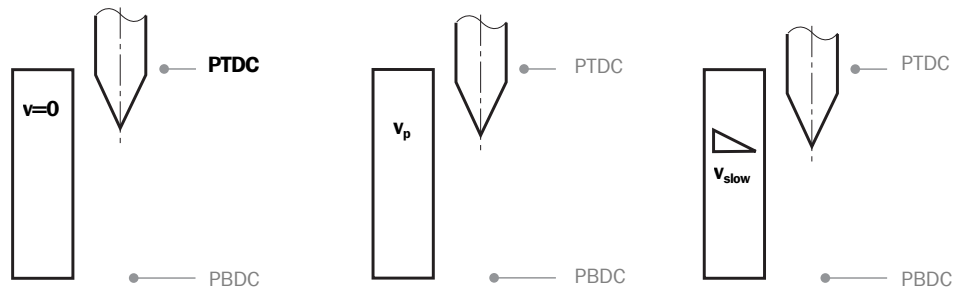

System state

- Red
- Yellow
- Green

- Red
- Yellow
- Green

- Red
- Yellow
- Green

7-segment display



Start signal for closing movement



Request signal v_{slow}



OSSD



Request signal for teach-in



Step 7 The request signal for v_{slow} is cancelled. The die accelerates to the high closing speed v_p .

Step 8 The workpiece interrupts the protective volume. The OSSDs go into the OFF state and generate a safe stop signal. From this the pinch point **PP** (workpiece surface) is obtained.

Step 9 The die must stop at least 5 mm above the workpiece. The positions for the switch-over and muting points are calculated. The operator cancels the start signal (foot switch).

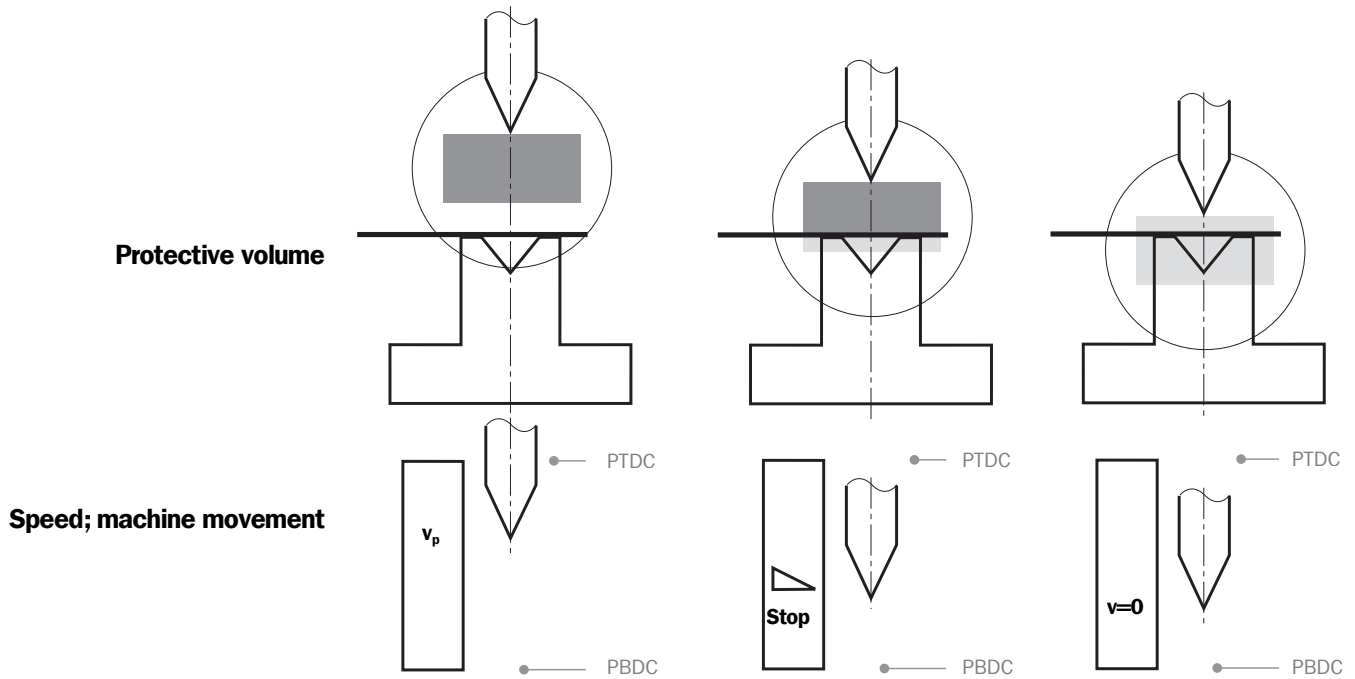

System state	<ul style="list-style-type: none"> <input type="radio"/> Red <input type="radio"/> Yellow <input checked="" type="radio"/> Green 	<ul style="list-style-type: none"> <input checked="" type="radio"/> Red <input type="radio"/> Yellow <input type="radio"/> Green 	<ul style="list-style-type: none"> <input type="radio"/> Red <input type="radio"/> Yellow <input checked="" type="radio"/> Green
7-segment display			
Start signal for closing movement	<input checked="" type="checkbox"/>	<input checked="" type="checkbox"/>	<input type="checkbox"/>
Request signal v_{slow}	<input type="checkbox"/>	<input type="checkbox"/>	<input type="checkbox"/>
OSSD	<input checked="" type="checkbox"/>	<input type="checkbox"/>	<input checked="" type="checkbox"/>
Request signal for teach-in	<input type="checkbox"/>	<input type="checkbox"/>	<input type="checkbox"/>

V 4000 PB

- Step 10** The operator gives the signal once more to start the closing movement (foot switch). The operating cycle resumes on the basis of this position. The protective volume is muted as soon as the gap is ≤ 6 mm and the V 4000 PB has reached the muting point **MP**. The V 4000 PB has updated the parameters and the first bending without discarding of material can be made after giving a new start signal.

Protective volume

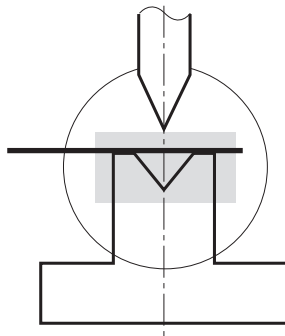

Speed; machine movement

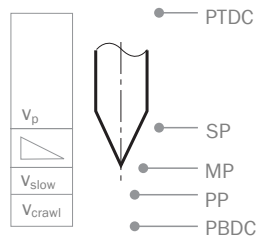

System state

- Red
- Yellow
- Green

7-segment display



Start signal for closing movement



Request signal v_{slow}



OSSD



Request signal for teach-in



3.7.2 Teach-in

Start condition: press is wide open

- Step ①** The die is at any point in the operating cycle. The operator gives the signal for teach-in (teach-in button). The protective volume is active.
- Step ②** The operator gives the signal to start the closing movement (foot switch). The die descends at high closing speed v_p . The entire protective volume is active.
- Step ③** The workpiece interrupts the protective volume. The OSSDs go into the OFF state and generate a safe stop signal. From this the pinch point **PP** (workpiece surface) is obtained.

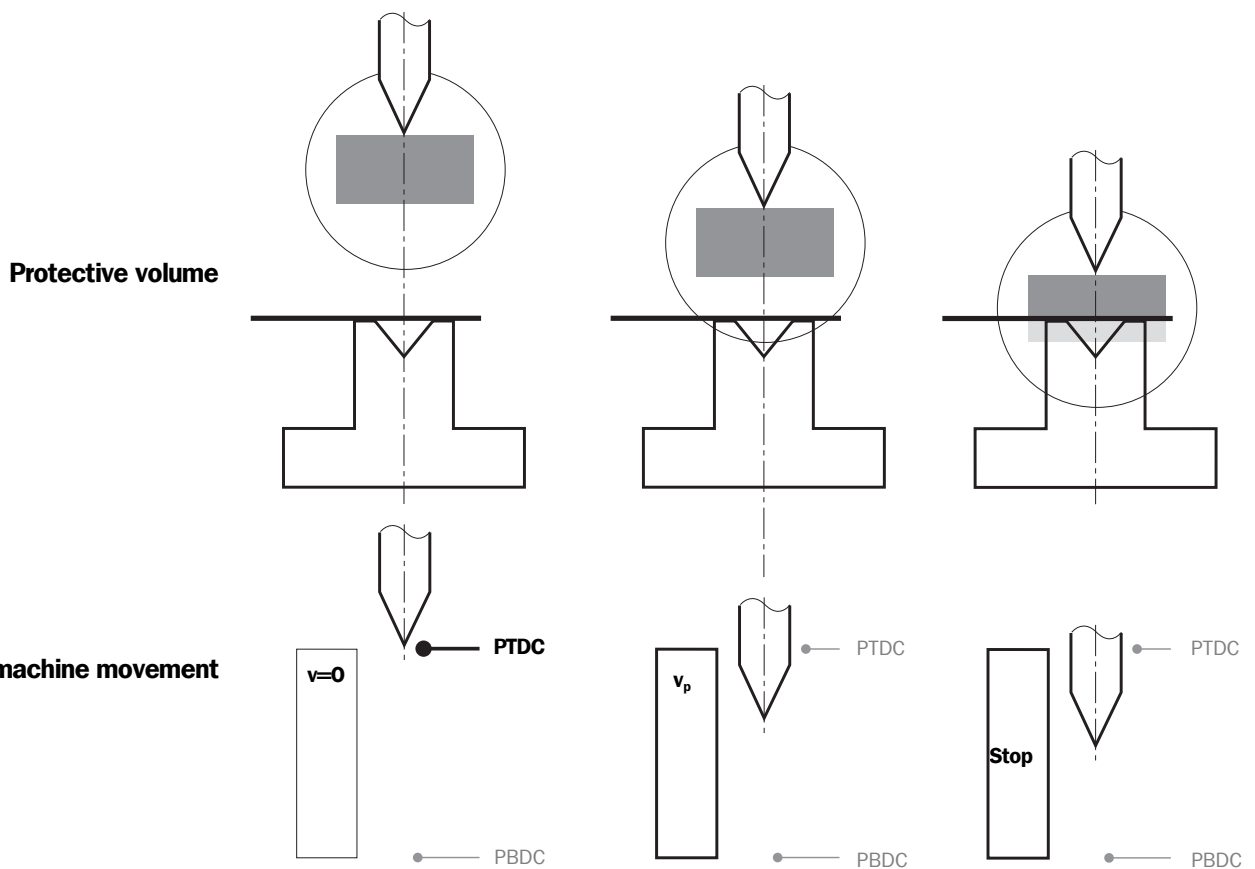

System state	● Red ⦿ Yellow ○ Green	○ Red ○ Yellow ● Green	● Red ○ Yellow ○ Green
7-segment display			
Start signal for closing movement	<input type="checkbox"/>	<input checked="" type="checkbox"/>	<input checked="" type="checkbox"/>
Request signal v_{slow}	<input type="checkbox"/>	<input type="checkbox"/>	<input type="checkbox"/>
OSSD	<input type="checkbox"/>	<input checked="" type="checkbox"/>	<input type="checkbox"/>
Request signal for teach-in	<input checked="" type="checkbox"/>	<input type="checkbox"/>	<input type="checkbox"/>

V 4000 PB

- Step ④** The die must stop at least 5 mm above the workpiece surface. The positions for the switch-over and muting points are calculated.
- Step ⑤** The operator gives the signal once more to start the closing movement (foot switch). The operating cycle resumes on the basis of this position. The protective volume is muted as soon as the gap is ≤ 6 mm and the V 4000 PB has reached the muting point **MP**. The first bending without discarding of material can be completed.

Protective volume

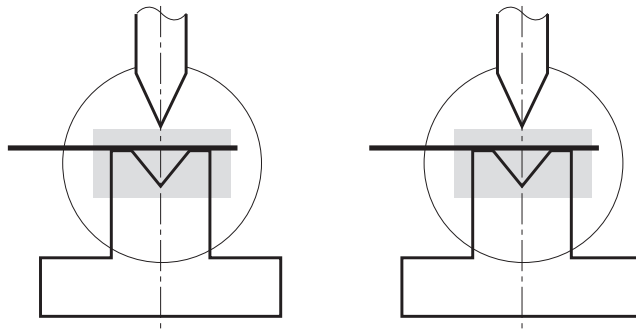

Speed; machine movement

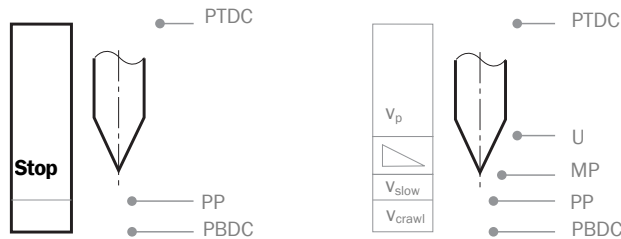

System state

- | | |
|----------|----------|
| ● Red | ○ Red |
| ○ Yellow | ○ Yellow |
| ○ Green | ● Green |

7-segment display



Start signal for closing movement



Request signal v_{slow}



OSSD



Request signal for teach-in



3.7.3 Standard mode

- Step ①** The die is at the programmed top dead centre **PTDC**. The operator gives the signal to start the closing movement (foot switch).
- ②** The die descends at high closing speed ($\cong v_p$). The entire protective volume is active.
- ③** At the switch-over point **SP** the target speed is requested by the V 4000 PB. The press controller starts the braking procedure. The protective volume stays active in the gap opening.

Protective volume

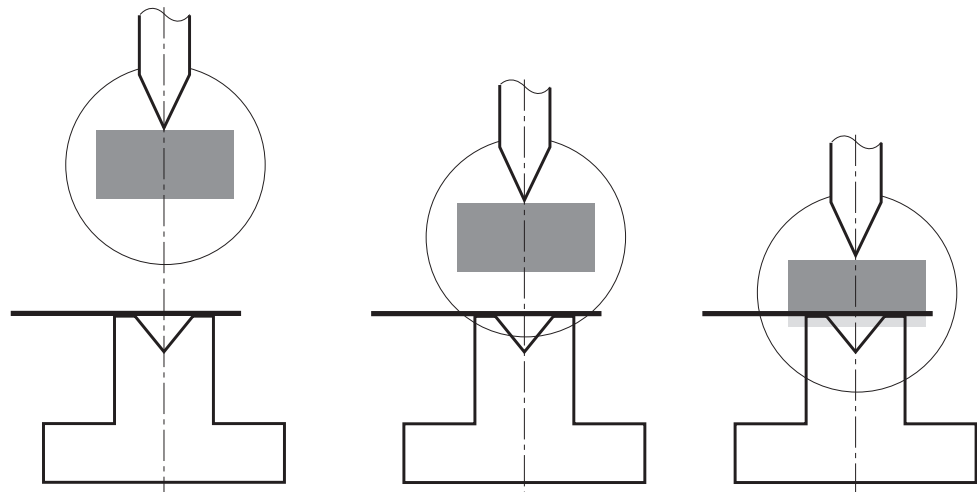

Speed; machine movement

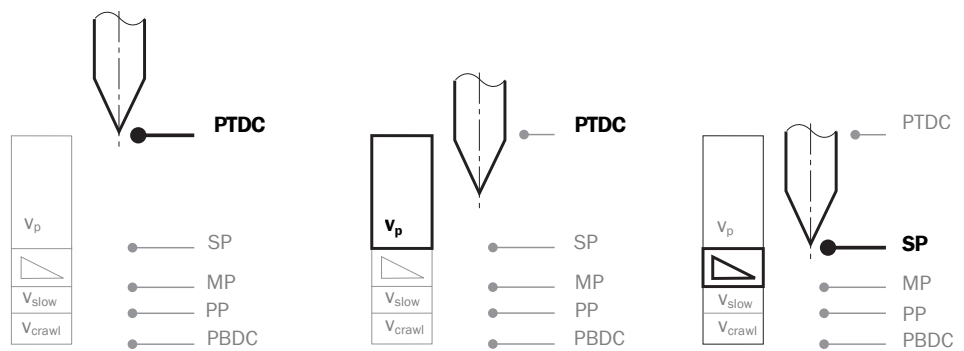

System state

- | | | |
|----------|----------|----------|
| ○ Red | ○ Red | ○ Red |
| ○ Yellow | ○ Yellow | ○ Yellow |
| ● Green | ● Green | ● Green |

7-segment display

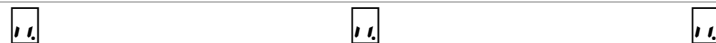

Start signal for closing movement



Request signal v_{slow}

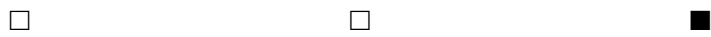

OSSD



V 4000 PB

- Step ④** At the muting point **MP** the gap size is 6 mm and the target speed has been reached. The protective volume becomes inactive.
- Step ⑤** The die contacts the workpiece at the pinch point **PP**.
- Step ⑥** The die shapes the workpiece. The operating cycle ends at the programmed bottom dead centre **PBDC** and the die goes back-up.

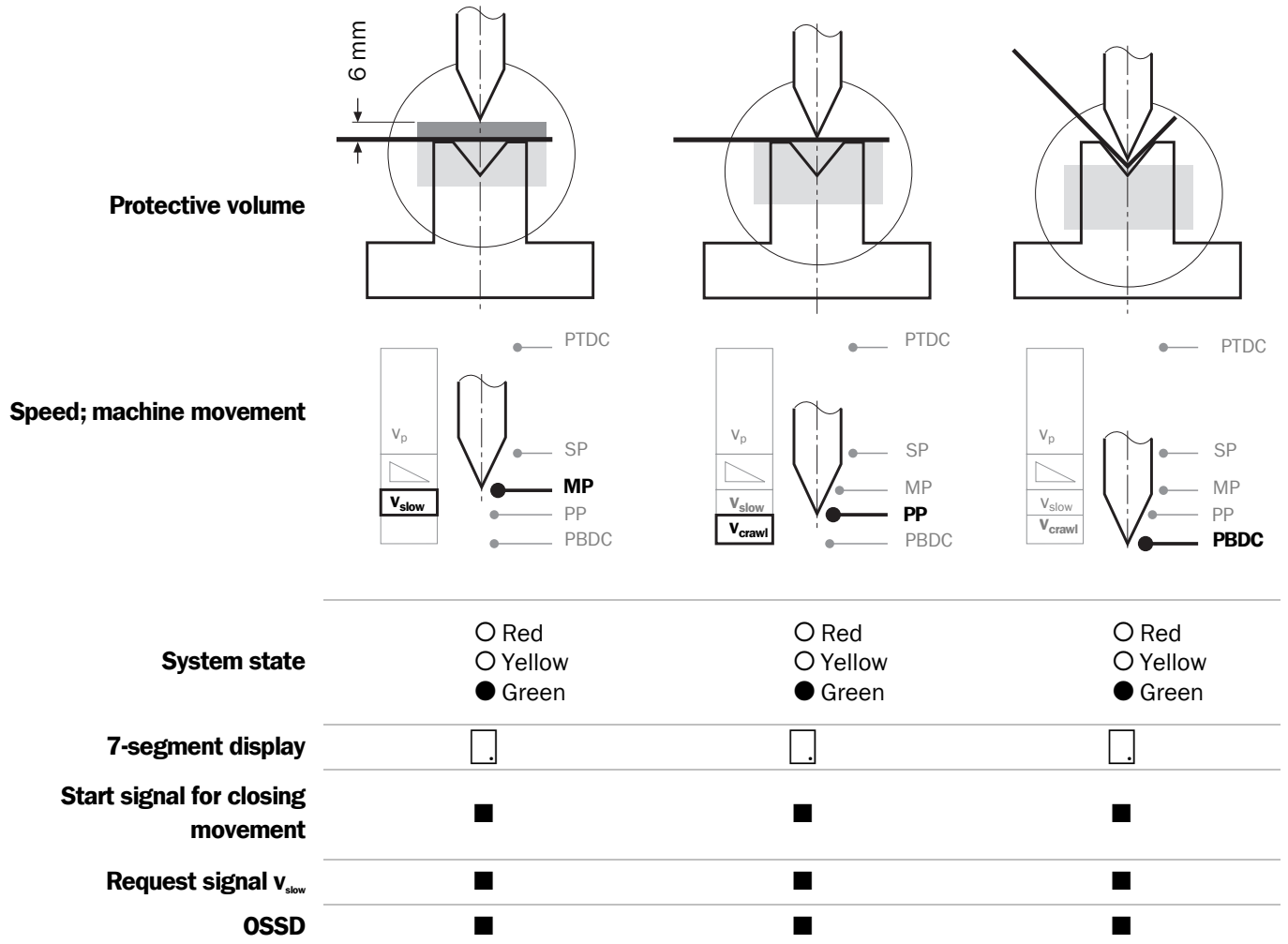

3.7.4 Box mode

- Step ①** The die is at the programmed top dead centre **PTDC**. The operator gives the signal to start the closing movement (double-click with the foot switch).
- ②** The die descends at high closing speed ($\cong v_p$). The entire protective volume is active.
- ③** If the box projects into the protective volume in front of the pressure axis, the protective volume in front of the pressure axis will be automatically blanked. The die continues to descend at maximum speed v_p . The part of the protective volume behind the pressure axis remains active.

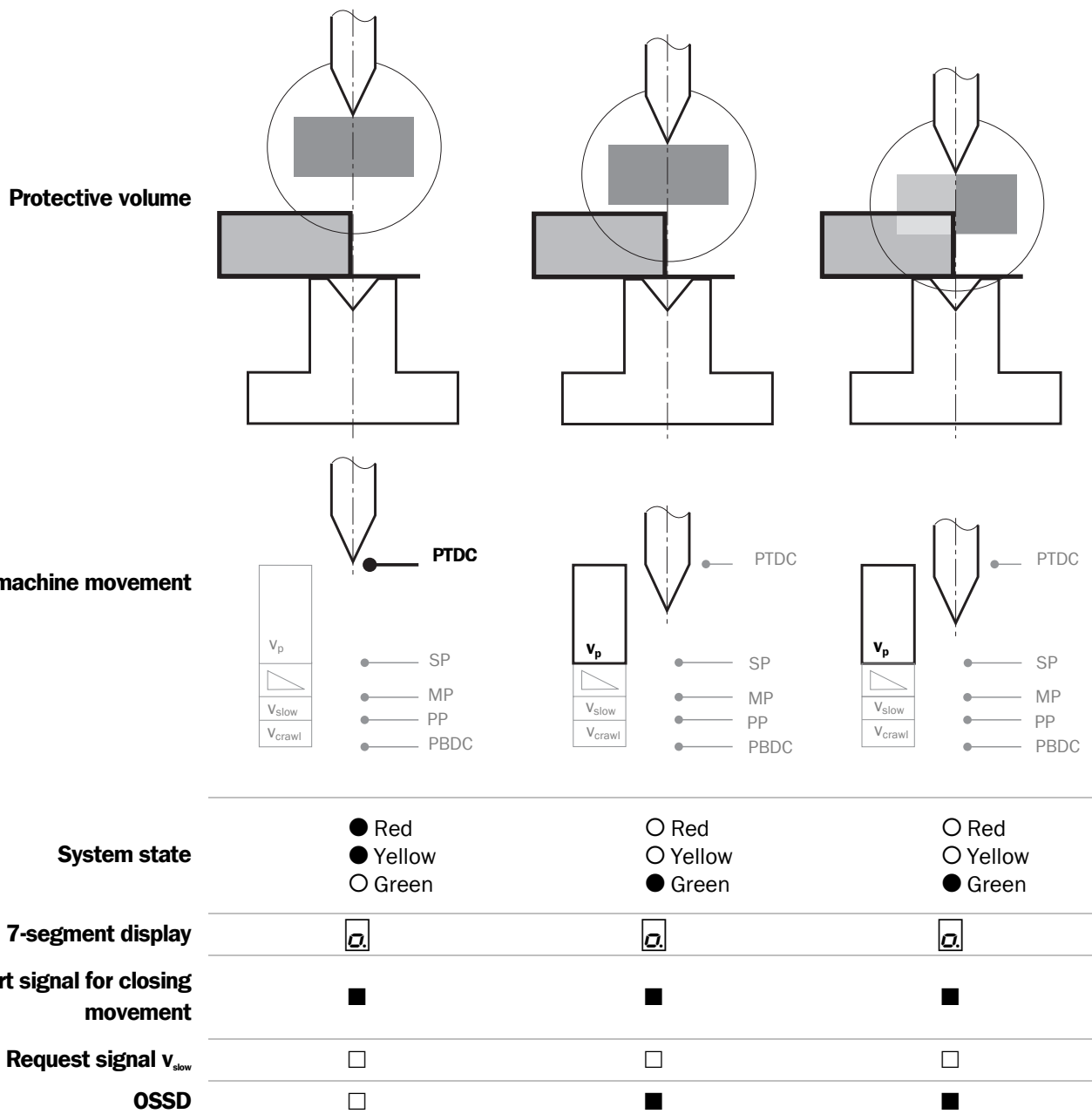

V 4000 PB

- Step ④** At the switch-over point **SP** the target speed is requested by V 4000 PB. The press controller starts the braking procedure. The protective volume segment remains active in the gap opening behind the pressure axis.
- Step ⑤** At the muting point **MP** the gap size is 6 mm and the target speed has been reached. The protective volume becomes inactive.
- Step ⑥** The die contacts the workpiece at the pinch point **PP**. The bending process is the same as with standard mode.

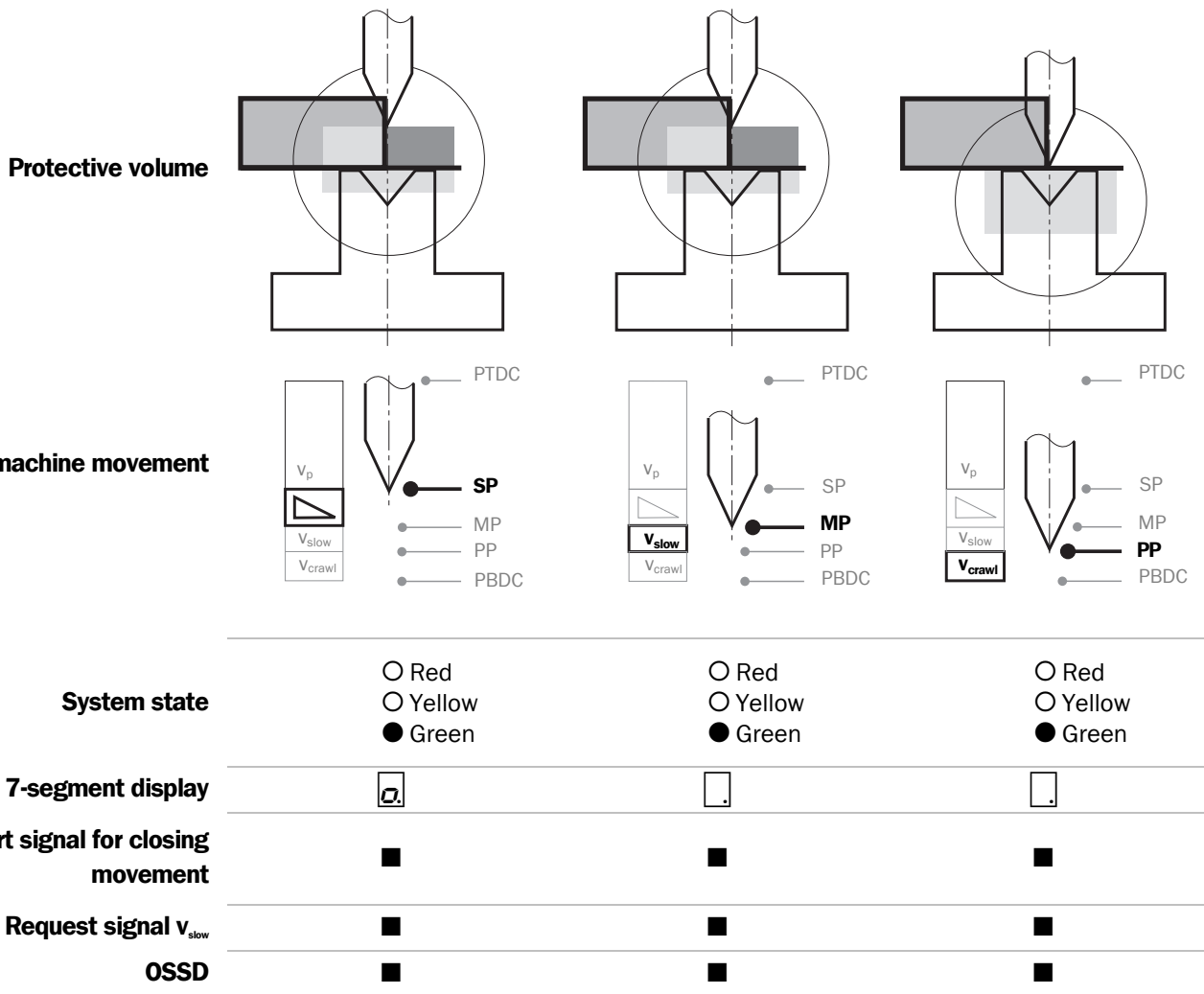

3.7.5 Back-stop mode

- Step ①** The die is at the programmed top dead centre **PTDC**. The operator gives the signal to start the closing movement (double-click with the foot switch).
- ②** The die descends at high closing speed ($\cong v_p$). A reduced protective volume segment behind the pressure axis is active.
- ③** At the switch-over point **SP** the target speed is requested by the V 4000 PB. The press controller starts the braking procedure. The protective volume segment stays active in the gap opening.

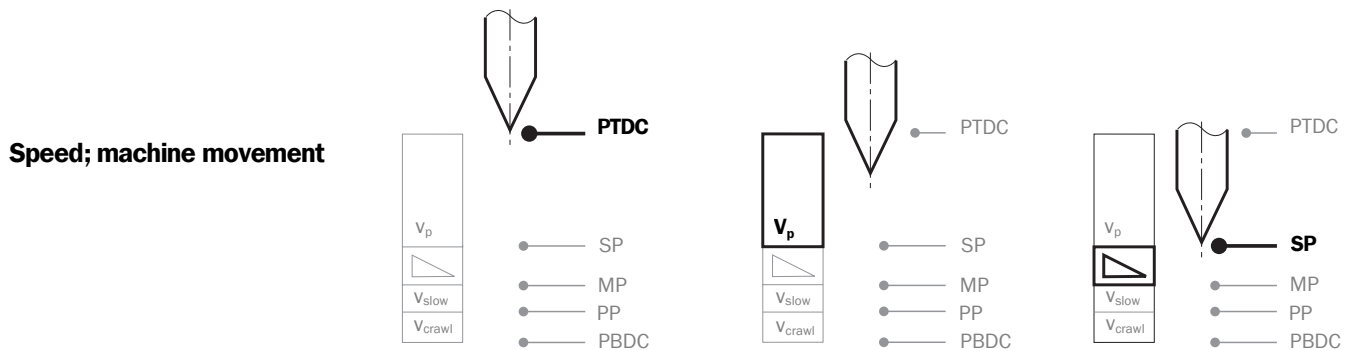
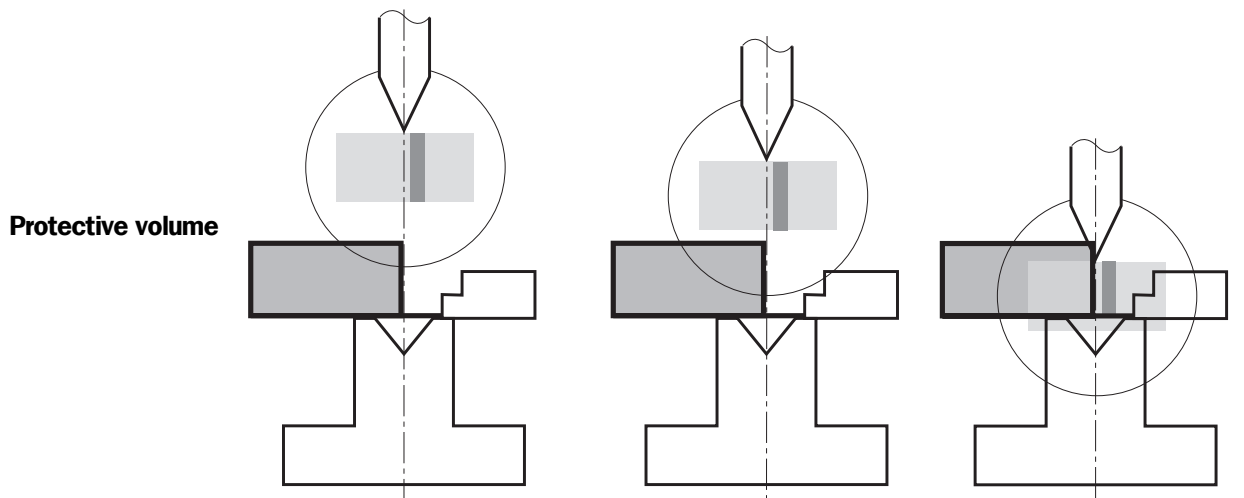

System state	<ul style="list-style-type: none"> ● Red ● Yellow ○ Green 	<ul style="list-style-type: none"> ○ Red ○ Yellow ● Green 	<ul style="list-style-type: none"> ○ Red ○ Yellow ● Green
7-segment display			
Start signal for closing movement	■	■	■
Request signal v_{slow}	□	□	■
OSSD	□	■	■

V 4000 PB

- Step ④** At the muting point **MP** the gap size is 6 mm and the target speed has been reached. The protective volume becomes inactive.
- Step ⑤** The die contacts the workpiece at the pinch point **PP**. The bending process is the same as with standard mode.

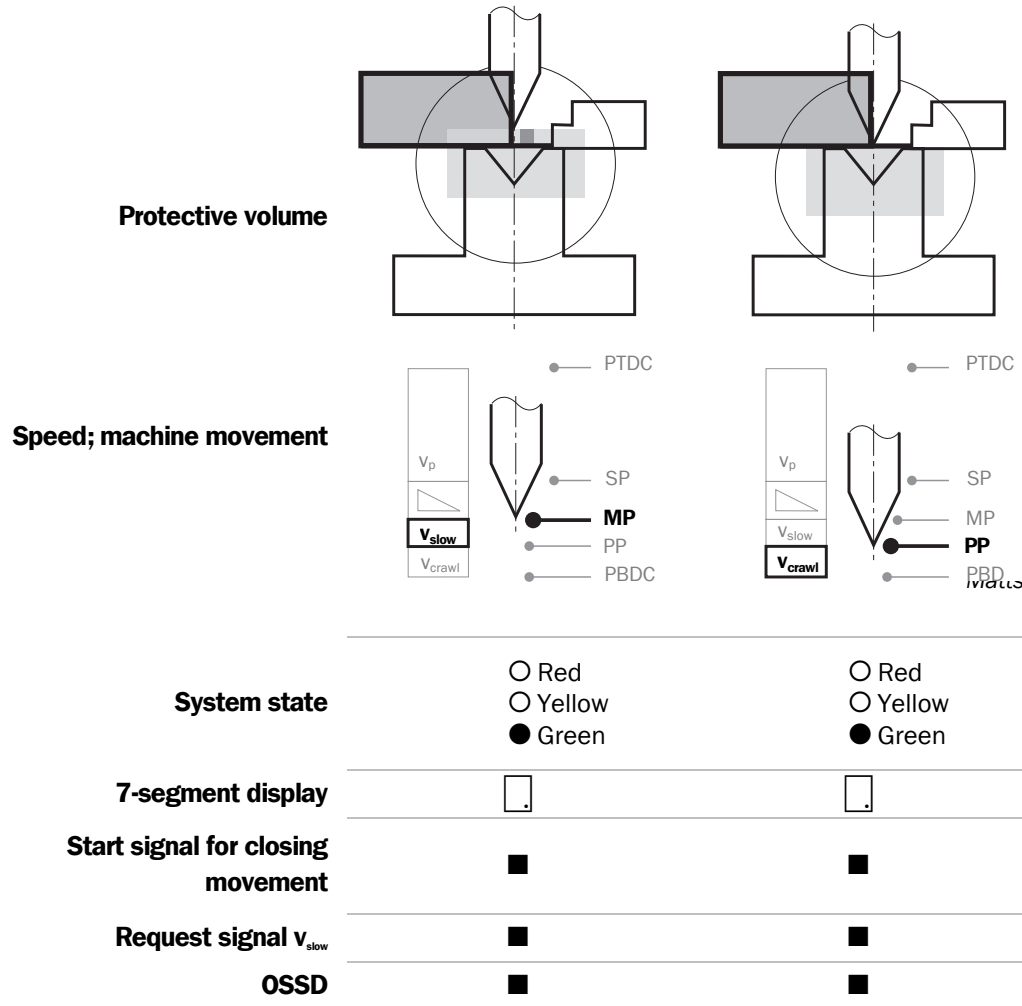

3.8 Alignment mode

The alignment operating mode helps the operator in aligning the sender and the receiver. When commissioning and every time there is a change of tooling, the sender and receiver need to be mechanically aligned with respect to each other beneath the die and with respect to the die tip.

The operator uses the alignment masks and the 7-segment display to align the sender and receiver exactly to each other and determines the optimum alignment of the protective volume to the die (see also Section 7.2 "Aligning sender and receiver").

The following applies to alignment mode:

- The protective volume is not active.
- The OSSDs are in the OFF state.
- The operator has no protection from the V 4000 PB.

Note In alignment mode the laser is visible. The V 4000 PB meets the requirements of laser protection class 1 M. There is no hazard for the operator.

➤ Do not look into the laser beam using optical equipment (such as binoculars).

4 Mounting

This chapter describes the preparation and completion of the mounting of the V 4000 PB.

The following steps are necessary after mounting:

- Electrical installation (Chapter 5)
- Configuration of the V 4000 PB (Chapter 6)
- Aligning sender and receiver (Section 7.2)

4.1 Steps for mounting



WARNING

Pay particular attention to the following points during mounting:

- Mount the V 4000 PB so that it is protected against moisture, contamination and damage.
- Ensure that the viewing field of the front lenses is not restricted.
- In the case of machines with high vibration levels, use a screw-locking compound to ensure mounting screws do not work themselves loose.
- Check the mounting screws regularly to ensure they are still tight.

Note The sender and the receiver are mounted on the press crosshead in the same way.

4.1.1 Mounting the sender or receiver using SICK mounting kit 1

Preparation of the bracket on the press crosshead:

The SICK mounting kit 1 consists of an alignment plate with a sliding nut.

Your bracket on the press crosshead must have a corresponding groove (for dimensions, see Fig. 24). The groove must be at least 100 mm long. In addition a free space must be left for the front mounting bolt of the sender or receiver.

Fig. 24: Groove for accommodating the sliding nut

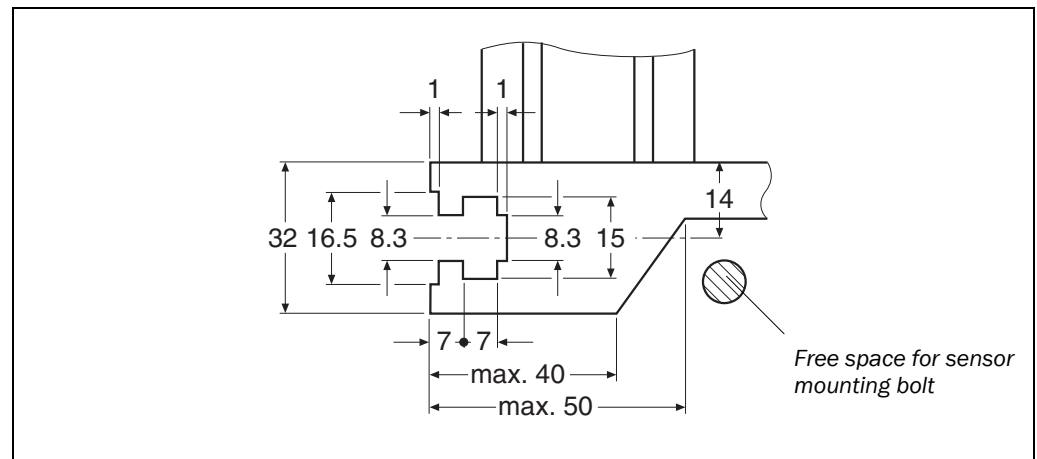

Mounting your V 4000 PB with the SICK mounting kit 1:

Fig. 25: Mounting using SICK mounting kit 1

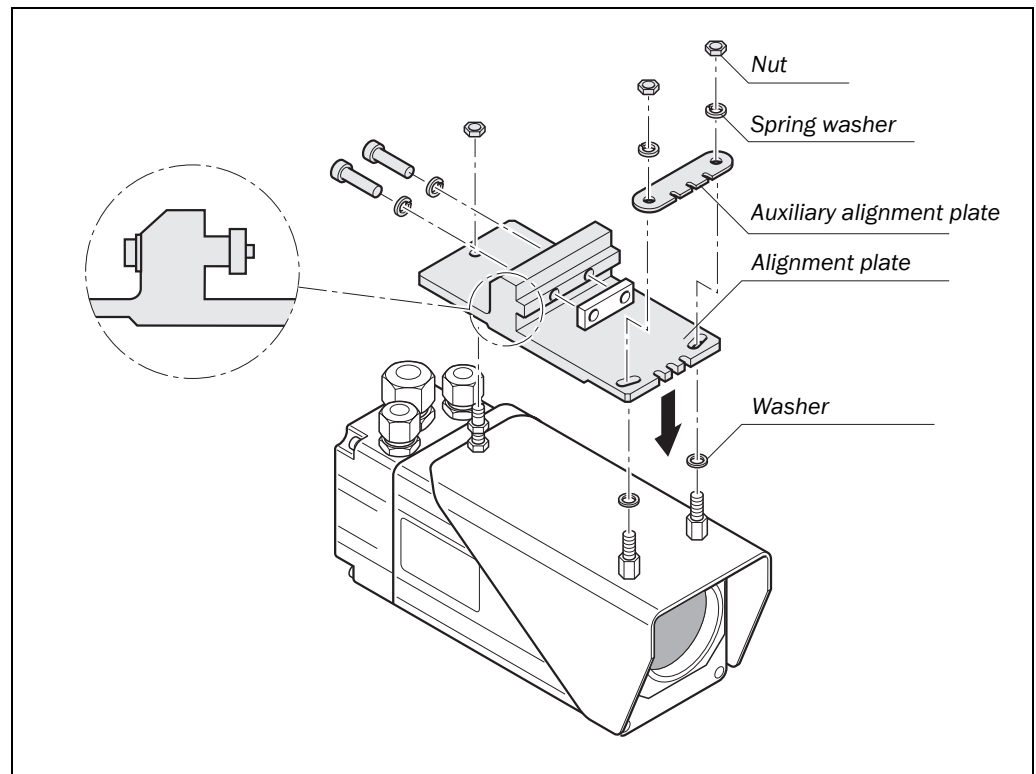

Note When installing mounting kit 1 make sure the supplied spring washers, plain washers, nuts and auxiliary alignment plate are positioned correctly.

- Fasten the alignment plate to the sender or receiver.
- Slide the alignment plate with the sender or receiver into the groove prepared for it in your bracket.

Note In back-stop mode, the active protective volume segment as seen from the operator side is behind the pressure axis. This is why you will need to specify via the CDS in the configuration on which side of the press brake the receiver is mounted.

4.1.2 Mounting the sender or receiver using SICK mounting kit 2

SICK mounting kit 2 consists of a device adapter with a groove for mounting the sliding nut (SICK mounting kit 1) and a retaining arm which is mounted on the press crosshead. The retaining arm has a rapid adjustment device for the vertical axis and an adjustment lever in the direction of the press crosshead.

Latching marks are provided on the vertical profile of the retaining arm to allow rapid adjustment of the V 4000 PB for frequent tool changes.

V 4000 PB

Fig. 26: SICK mounting kit 2

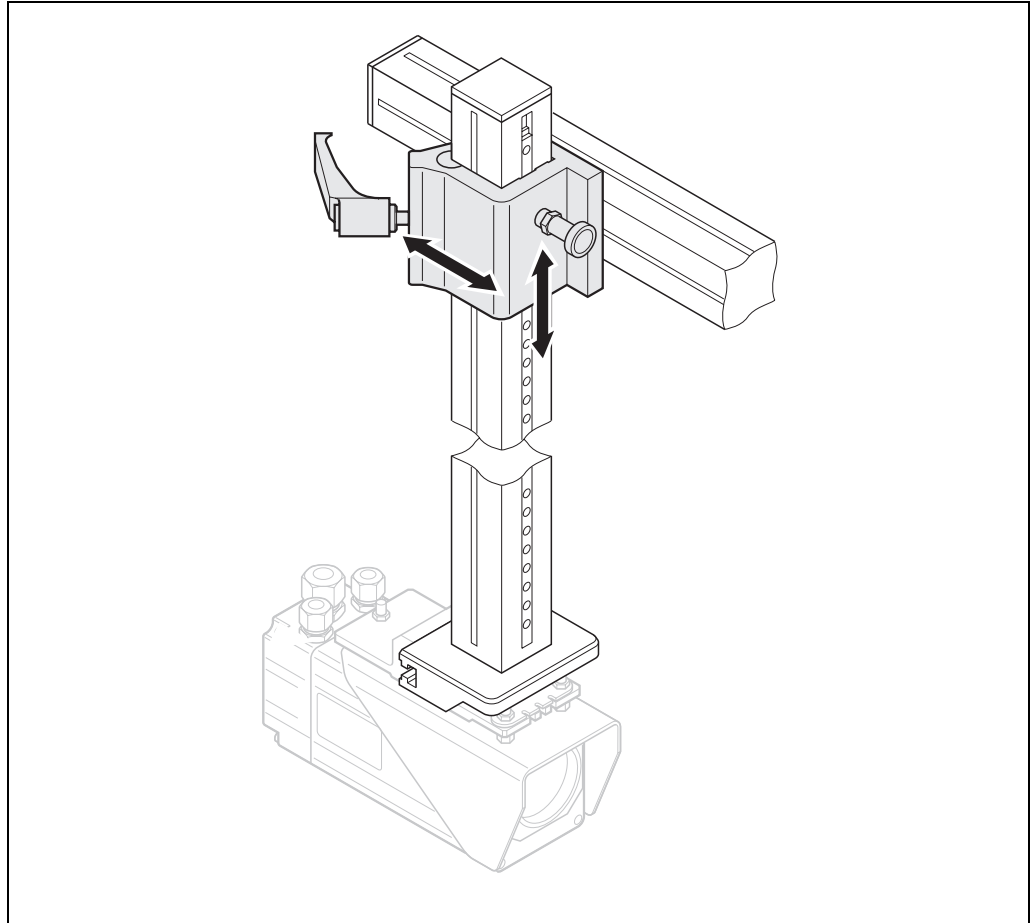

➤ To mount SICK mounting kit 2, read the instructions sheet supplied with the kit.

4.1.3 Sticker: Information for daily inspection

- Once mounting is completed, you will need to attach the self-adhesive information note supplied entitled "**Information for daily inspection**".
- Use only the information label in the language which the operators of the machine speak and understand.
 - Affix the information label such that it is easily visible by the operators during operation. After attaching additional objects and equipment, the information label must not be concealed from view.

5 Electrical installation



WARNING

Switch off the machine!

The machine could start unintentionally during electrical installation work.

➤ Ensure that the entire system is de-energised during the electrical installation.

Note

- To ensure the specified electromagnetic compatibility (EMC), functional earthing (FE) must be connected.
- The external voltage supply of the devices must be capable of buffering brief mains voltage failures of 20 ms as specified in EN 60 204. Suitable power supplies are available as accessories from SICK (Siemens type series 6 EP 1).
- Make sure the V 4000 PB is protected by the appropriate fusing. The electrical data you will need in order to ascertain the fuse ratings will be found in Chapter 10 "Technical data" in Table 30 on Page 103.

5.1 Connecting the receiver

Fig. 27: Pin assignments of digital interface

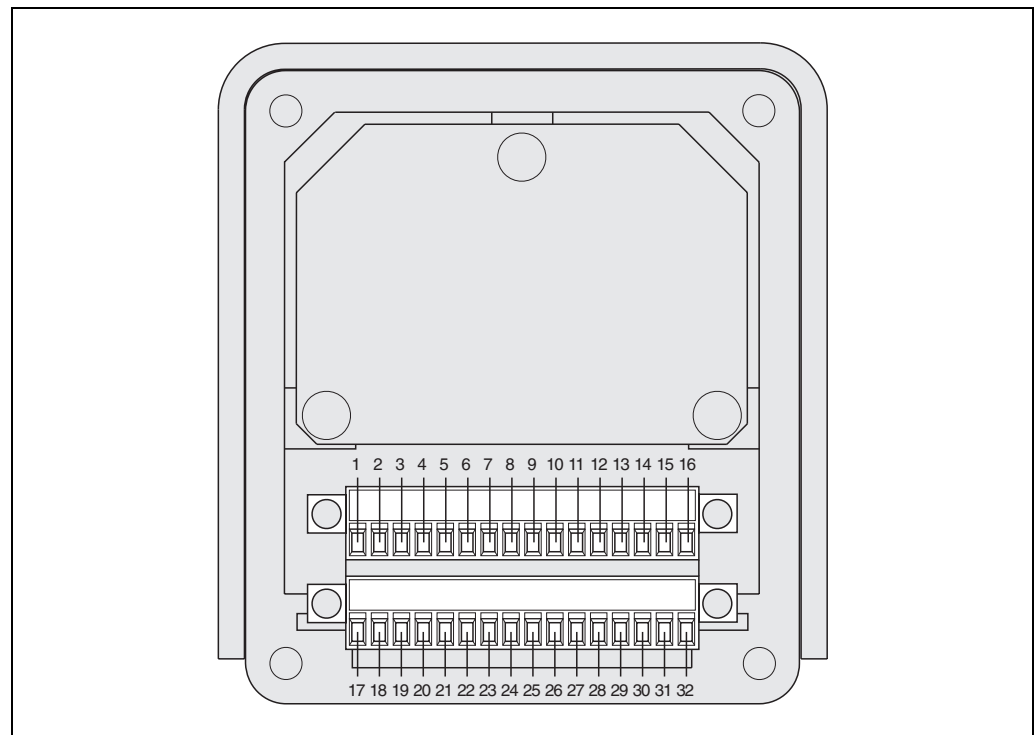

V 4000 PB

Tab. 9: Pin assignment of digital interface

Pin	Signal	Function
1	OSSD2	OSSD2 (switching output 2), 0.5 A
2	OSSD1	OSSD1 (switching output 1), 0.5 A
3	EDM	Input, external device monitoring (EDM)
4	START	Safe 24 V input, gated signal for starting the closing movement
5	NSTART	Safe 24 V input, complementary, gated signal for starting the closing movement
6	BYPASS_OUT1	Pulsed output (bypass signal)
7	VSLOW_REQ	Output, request signal for target speed
8	BYPASS_OUT2	Pulsed output (bypass signal)
9	TEACH_REQ	Output, request signal for teach-in mode
10	BYPASS_IN1	Input, bypass signal
11	TEACH_BUTTON	Input, signal for teach-in mode
12	BYPASS_IN2	Input, bypass signal
13	ADJ_BUTTON	Input, signal for alignment mode
14	DMODE3	Input, signal for back-stop protective volume mode
15	DMODE2	Input, signal for box protective volume mode
16	DMODE1	Input, signal for standard protective volume mode
17	NC	Reserved
18	GND	0 V DC input (voltage supply)
19	+24V	24 V DC input (voltage supply)
20	24V_SENDER	24 V DC output (sender voltage supply) 200 mA
21	GND	0 V DC input (sender voltage supply)
22	SEND-	Output, for differential signal to the sender
23	SEND+	Output, for differential signal to the sender
24	ENCO1+	Input, signal from PBI
25	ENCO1-	Input, signal from PBI
26	ENCO2+	Input, signal from PBI
27	ENCO2-	Input, signal from PBI
28	ENCO_GND	0 V DC input
29	TXD_232 / 422_TXD-	Output, connection for serial configuration interface RS-232 / RS-422 (double assignment, can be set via switch S)
30	RXD_232 / 422_TXD+	Output, connection for serial configuration interface RS-232 / RS-422 (double assignment, can be set via switch S)
31	GND / 422_RXD-	Input, connection for serial configuration interface RS-232 / RS-422 (double assignment, can be set via switch S)
32	422_RXD+	Input, connection for serial configuration interface RS-422

Fig. 28: Connection diagram for receiver

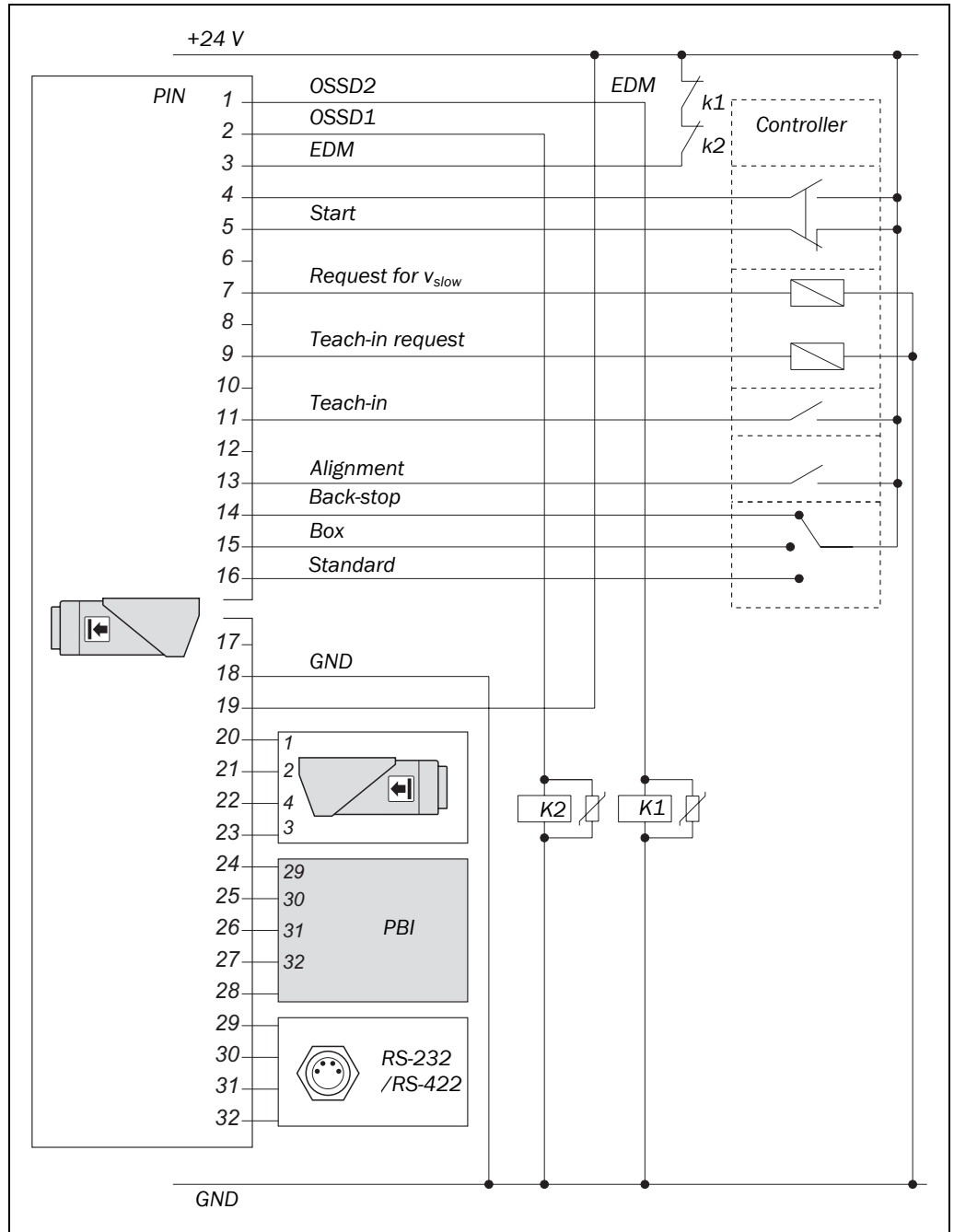
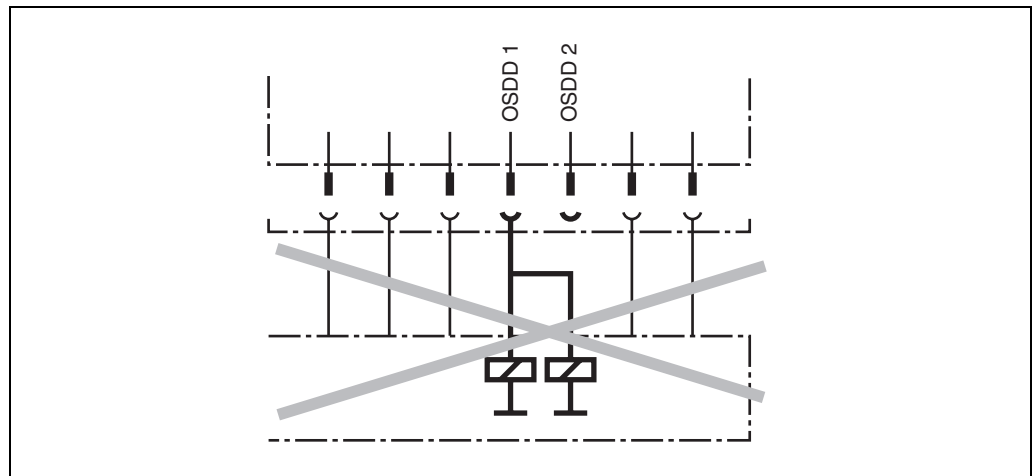

Fig. 29: OSSDs connection



V 4000 PB

- Note** The machine controller must process the signals from OSSD1 and OSSD2 separately. OSSD1 and OSSD2 must not be connected together.
- To ensure signal integrity connect OSSD1 and OSSD2 separately to the machine controller (see also Fig. 28).

5.2 Connecting the sender

Fig. 30: Pin assignments of the sender

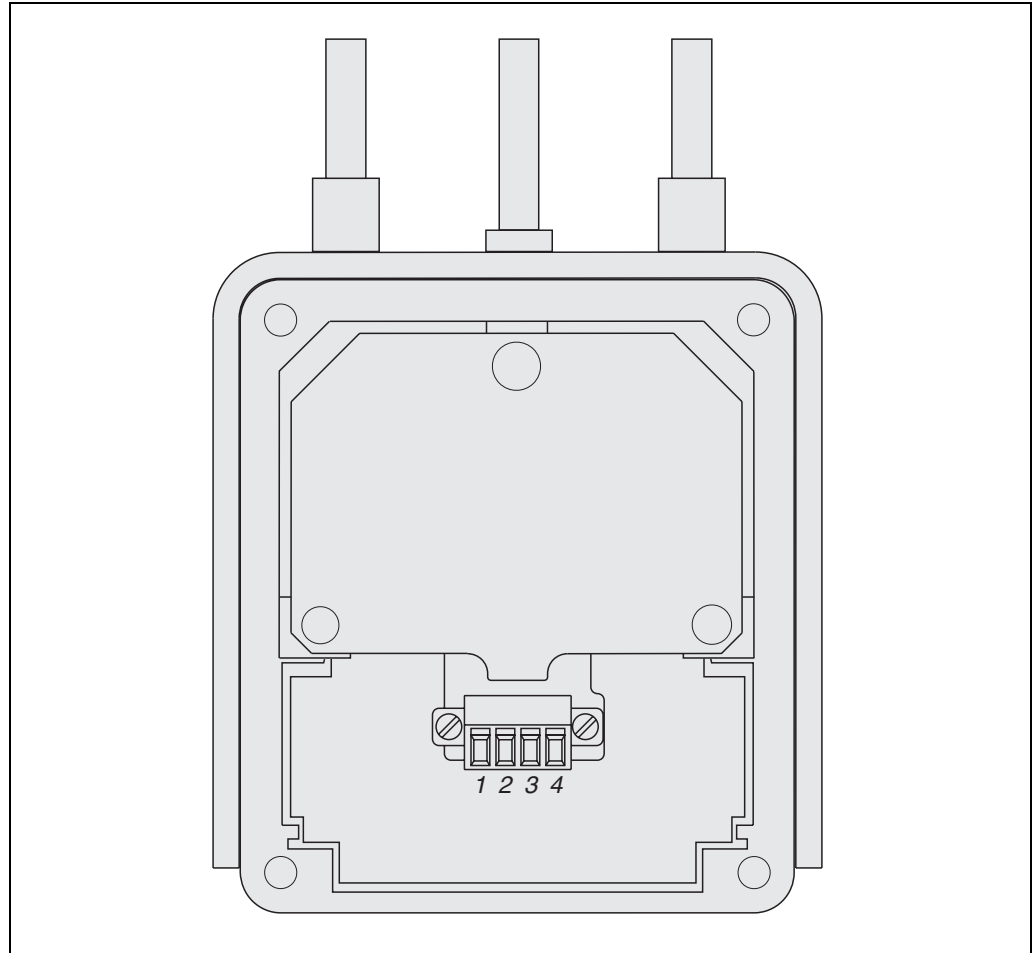

Tab. 10: Pin assignments of the sender

Pin	Signal	Function
1	+24V	24 V DC input (voltage supply)
2	GND	0 V DC input (voltage supply)
3	SEND+	Input, signal from receiver
4	SEND-	Input, signal from receiver

5.3 Making up the connections for receiver and sender

➤ Always use EMC-type cable glands for all through-holes.

The following cable glands are supplied:

Tab. 11: Cable glands

Cable gland	Cable diameter
Receiver wiring space (3 through-holes)	
M20	7–12 mm
M16 (x 2)	3–7 mm
Sender wiring space (1 through-holes)	
M16	3–7 mm

➤ Use the following cable cross-sections for the individual connections:

Tab. 12: Cable cross-sections

Cable	Recommended cable	Screened	Usable as trailing cable	Other requirements
Receiver to control cabinet (M20)	18 wires, 0.34 - 0.5 mm ²	Yes	Yes	-
Receiver to sender (M16)	4 wires, 0.34 mm ²	Yes	No	2 twisted pairs for RS-422
Receiver to PBI (M16)	4 wires, 0.34 mm ²	Yes	Yes	2 twisted pairs for RS-422

5.4 Connecting the PBI

Fig. 31: Pin assignments of the PBI

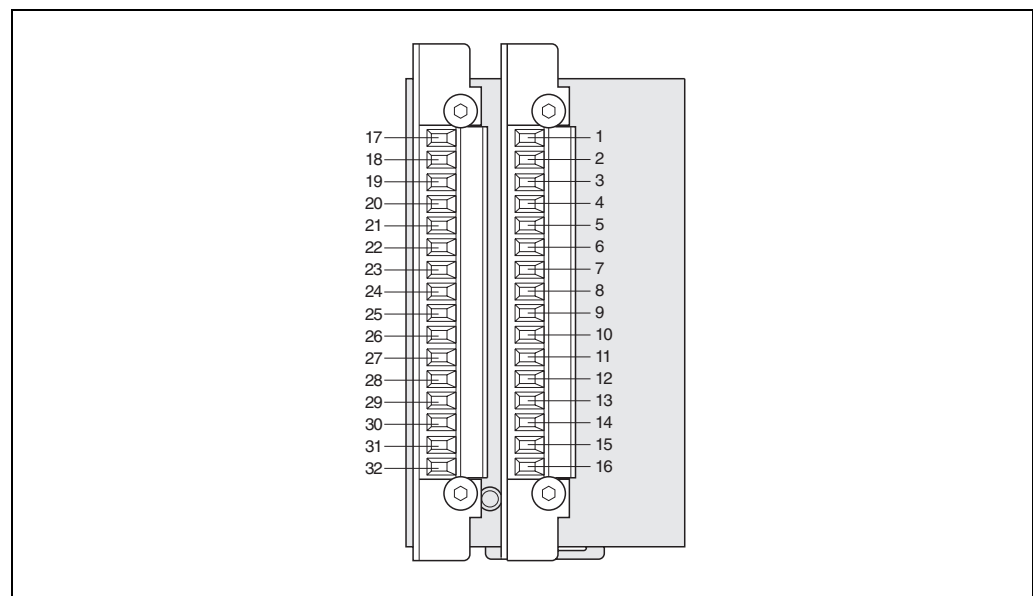

V 4000 PB

Tab. 13: Pin assignments of the PBI

Pin	Signal	Function
1	UA0+	Input (RS-422), reference mark
2	UA0-	Input (RS-422), reference mark
3	UA1+	Input (RS-422), 0° signal from incremental encoder
4	UA1-	Input (RS-422), 0° signal from incremental encoder
5	UA2+	Input (RS-422), 90° signal from incremental encoder
6	UA2-	Input (RS-422), 90° signal from incremental encoder
7	Shield	Shield
8	UP_5V	5 V DC output (voltage supply for incremental encoder)
9	UN_0V	0 V DC output (voltage supply for incremental encoder)
10	Sense_5V	5 V DC input (for measurement of voltage supply at incremental encoder)
11	Sense_0V	0 V DC input (for measurement of voltage supply at incremental encoder)
12	UAS	Input, error signal from incremental encoder
13	Shield	Shield
14	+5V_Opt.	5 V DC output (optional voltage supply for incremental encoder), 0.15 A
15	GND	0 V DC input (voltage supply)
16	+24V	24 V DC input (voltage supply), 0.5 A
17	UA0+	Output (RS-422), reference mark
18	UA0-	Output (RS-422), reference mark
19	UA1+	Output (RS-422), signal to numerical control
20	UA1-	Output (RS-422), signal to numerical control
21	UA2+	Output (RS-422), signal to numerical control
22	UA2-	Output (RS-422), signal to numerical control
23	Shield	Cable shield
24	UP_5V	5 V DC input (voltage supply from numerical control for incremental encoder)
25	UN_0V	0 V DC input (voltage supply from numerical control for incremental encoder)
26	Sense_5V	5 V DC output (for measurement of supply voltage at incremental encoder)
27	Sense_0V	0 V DC output (for measurement of supply voltage at incremental encoder)
28	UAS	Output, error signal from the incremental encoder to numerical control
29	ENC01+	Output (RS-422), signal to the receiver
30	ENC01-	Output (RS-422), signal to the receiver
31	ENC02+	Output (RS-422), signal to the receiver
32	ENC02-	Output (RS-422), signal to the receiver

Fig. 32: PBI connection diagram

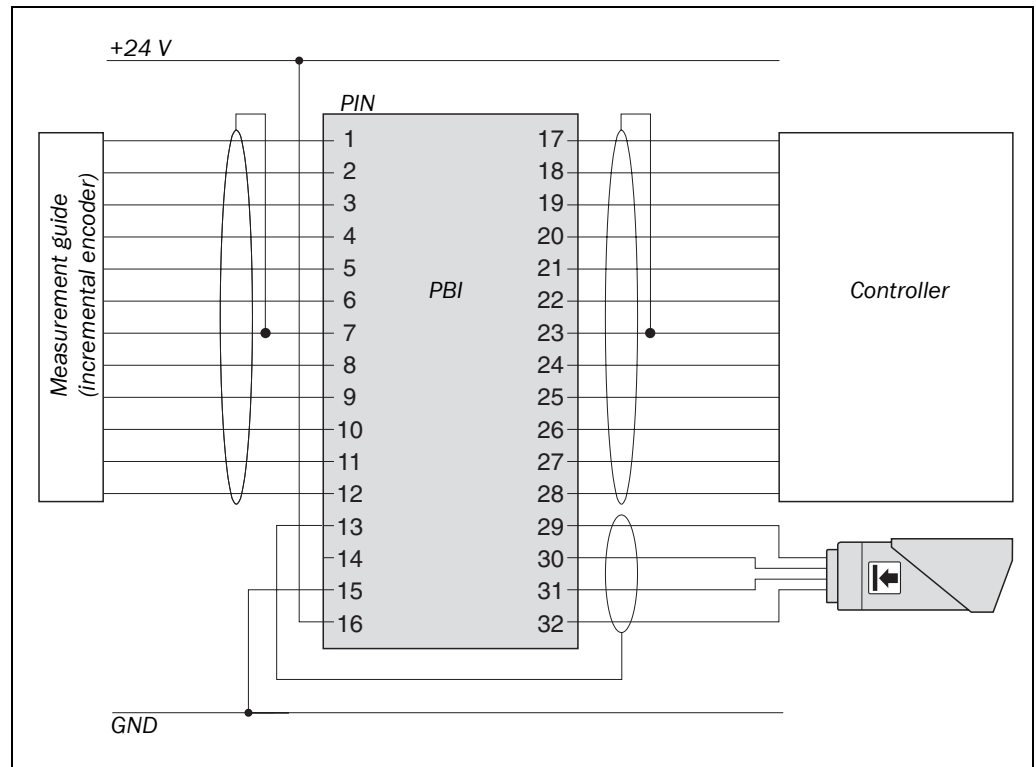

5.5 External device monitoring (EDM)

The EDM checks if the contacts actually de-energise when the protective device responds. If, after an attempted reset, the EDM does not detect a response from the switching amplifier within 300 ms, the EDM will deactivate the OSSD switching outputs again.

External device monitoring is implemented in such a way that there is positive closing of both N/C contacts (k1, k2) when the contact elements (K1, K2) reach their de-energised position after the protective device has responded. 24 V is then applied at the input of the EDM (see Fig. 28). If 24 V is not present after the response of the protective device, this means one of the contact elements is faulty and the external device monitoring prevents the machine starting up again.

Notes



- Contacts or relays monitored by EDM must be positively driven.
- If you connect the contact elements to be monitored to the EDM input, then you must activate the option EDM in the CDS (Configuration & Diagnostic Software). If you fail to do so, after the V 4000 PB is switched on the 7-segment display will show .
- If you later deselect the EDM option, pin 6 of the system plug must not remain connected to 24 V.

V 4000 PB

5.6 Bypass

In bypass mode the press brake can be operated without an activated V 4000 PB protective device. In bypass mode the OSSDs are in the ON state and all displays on the receiver are switched off. The V 4000 PB does not generate any output signals (target-speed request, teach-in request).

To activate bypass mode, the bypass function should be enabled in the configuration and the outputs of the bypass function at the receiver connected with its inputs.

The bypass is disabled by interrupting the electrical connection. When bypass mode is disabled, the V 4000 PB goes into restart interlock and requests a power-up cycle.

Fig. 33: Bypass connection diagram

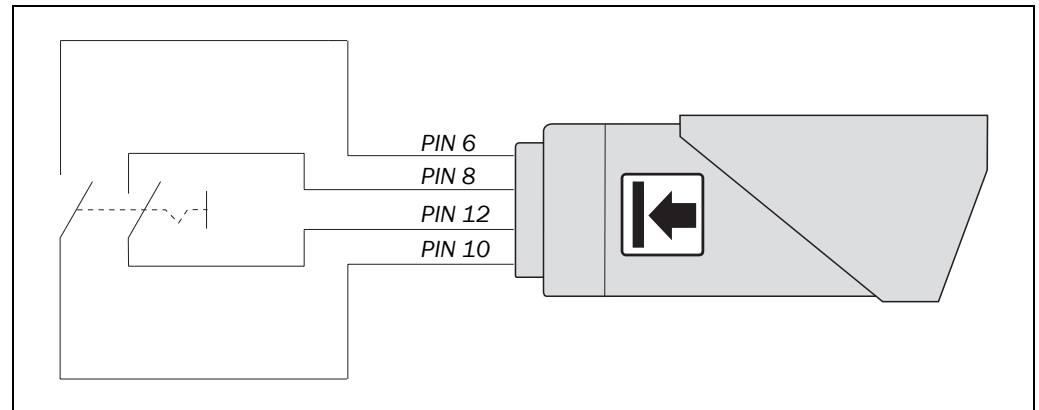

Notes



If you connect the bypass, you must activate the bypass function in the CDS (Configuration & Diagnostic Software). Should implausible states of the two input signals occur, the 7-segment display will show the error message .

The operator is responsible for the use and perfect functioning of additional safety devices which ensure the safe operation of the press brake (such as using robots for material handling).

5.7 Configuration connection (serial interface)

Fig. 34: Pin assignments for configuration interface

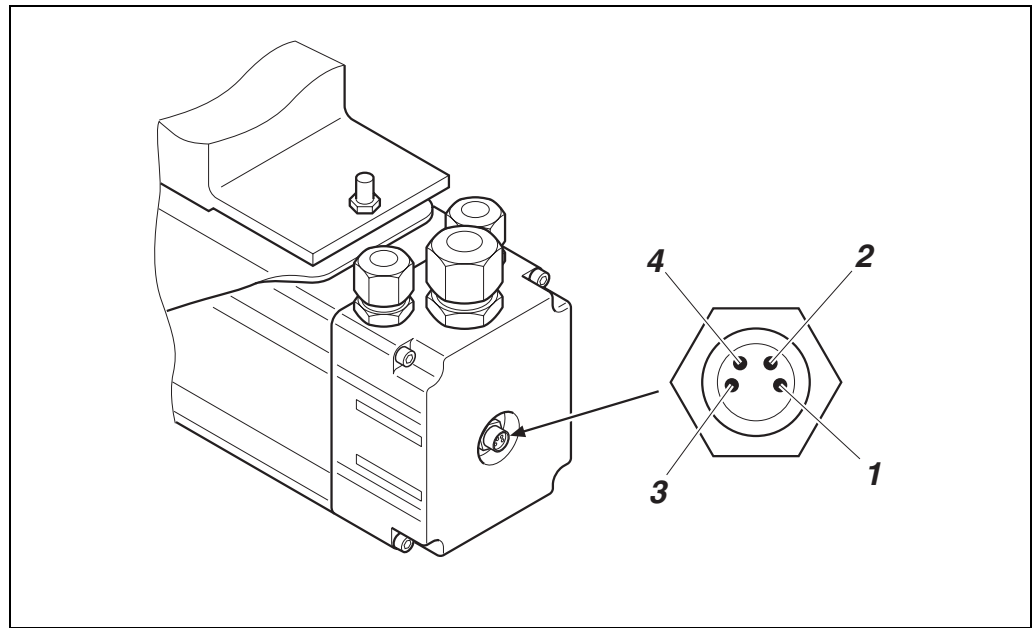

Switch S in position RS-422 (see Section 6.1)

Tab. 14: Pin assignment of permanent configuration connection with RS-422

Pin	Colour	Meaning	PC-side RS-422
1	Brown	422 RxD+	Pin 3 (TxD+)
2	White	422 TxD+	Pin 2 (RxD+)
3	Blue	422 RxD-	Pin 4 (TxD-)
4	Black	422 TxD-	Pin 1 (RxD-)

Switch S in position RS-232 (see Section 6.1)

Tab. 15: Pin assignments of temporary configuration connection with RS-232

Pin	Colour	Meaning	PC-side RS-232 SubD
1	Brown	-	NC
2	White	RxD	Pin 3
3	Blue	0 V DC (voltage supply)	Pin 5
4	Black	TxD	Pin 2

Notes The following instructions only apply when the V 4000 PB is connected temporarily with a PC.

- Connect the connecting cable to the configuration connection of the receiver.
- When configuration is finished, remove the connecting cable from the configuration connection.

6 Configuration

6.1 Delivery state

The V 4000 PB is delivered in a state which is safe.

- The V 4000 PB is in the **Waiting for configuration** device mode.
- The switching outputs (OSSDs) are in the OFF state.
- The 7-segment display shows .

Notes The maximum overall machine overrun and the maximum closing speed must be configured at installation such that they satisfy the condition of the stopping distance.

You can change this configuration with CDS.

The serial interface for configuration is switched to RS-232. In the case of a permanent – on-line – connection, the interface will need to be changed over to RS-422 with the switch S. The RS-422 interface must be supported on the PC or controller side and connected properly.

Fig. 35: Switch setting

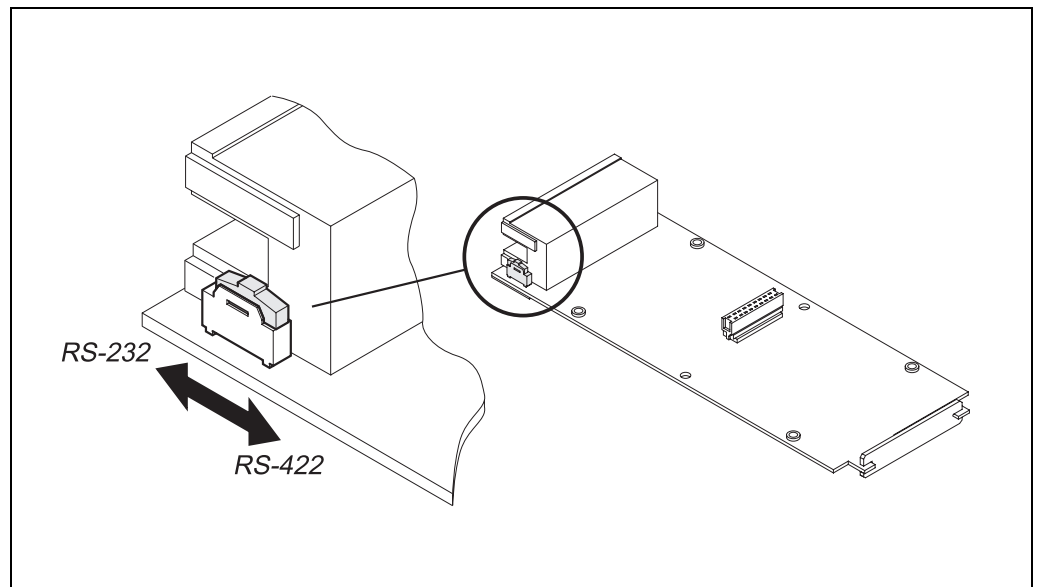

6.2 Configuration preparations

To configure the V 4000 PB you will need:

- CDS (Configuration & Diagnostic Software) on CD
- User manual for the CDS on CD
- A PC or notebook running Windows 9x / NT 4 / 2000 Professional / XP and with an RS-232 serial interface (the PC or notebook is not supplied)
- Connecting cable for connecting the PC and the V 4000 PB (SICK part no. 6 021 195)

How to prepare the configuration:

- Ensure that the V 4000 PB is properly mounted and connected electrically.
- Plan all the necessary settings (operating modes etc.).
- To configure the device, please read the user manual for the CDS (Configuration & Diagnostic Software) and use the on-line help function of the program.

Notes Should the V 4000 PB need to have repairs done by SICK, the configuration will be restored to its original state.

- For this reason you should back up your configuration on a separate data medium.

7

Commissioning



WARNING

Do not commission without a check by specialist personnel!

- Before you operate a system protected by the V 4000 PB for the first time, make sure that the system is first checked and released by specialist personnel.
- To this regard please read the notes in Chapter 2 "On safety " on Page 10.

Notes After replacing single components of the safety system a commissioning has to be done.

7.1 Test notes

The purpose of the tests described below is to confirm the safety requirements specified in the national and international rules and regulations, especially in the Machinery Directive and the Use of Work Equipment Directive (EC Conformity).

These tests are also intended as a way of detecting whether protection is being affected by sources of extraneous light or by other unusual environmental influences.

It is therefore essential that these tests be carried out.

7.2 Aligning sender and receiver

7.2.1 Initial alignment

Sender and receiver must be aligned exactly with respect to each other and with respect to the die of the press brake in order to ensure the safety function of the sensor. This is done with the alignment masks in alignment mode.

How to prepare for initial alignment:

- Ensure that the V 4000 PB is properly mounted and connected electrically.
- Ensure that the press is fitted with at least one die segment.
- Switch on the power supply to the V 4000 PB.

Recommendation To increase the accuracy of initial alignment, the press crosshead should be fitted with one die segment at the right-hand edge and one at the left.

Notes The laser is visible in alignment mode. The V 4000 PB meets the requirements of laser protection class 1M. The operator is not at any risk.

- Do not look into the laser beam with optical devices (such as a binoculars).

Fig. 36: Die segments

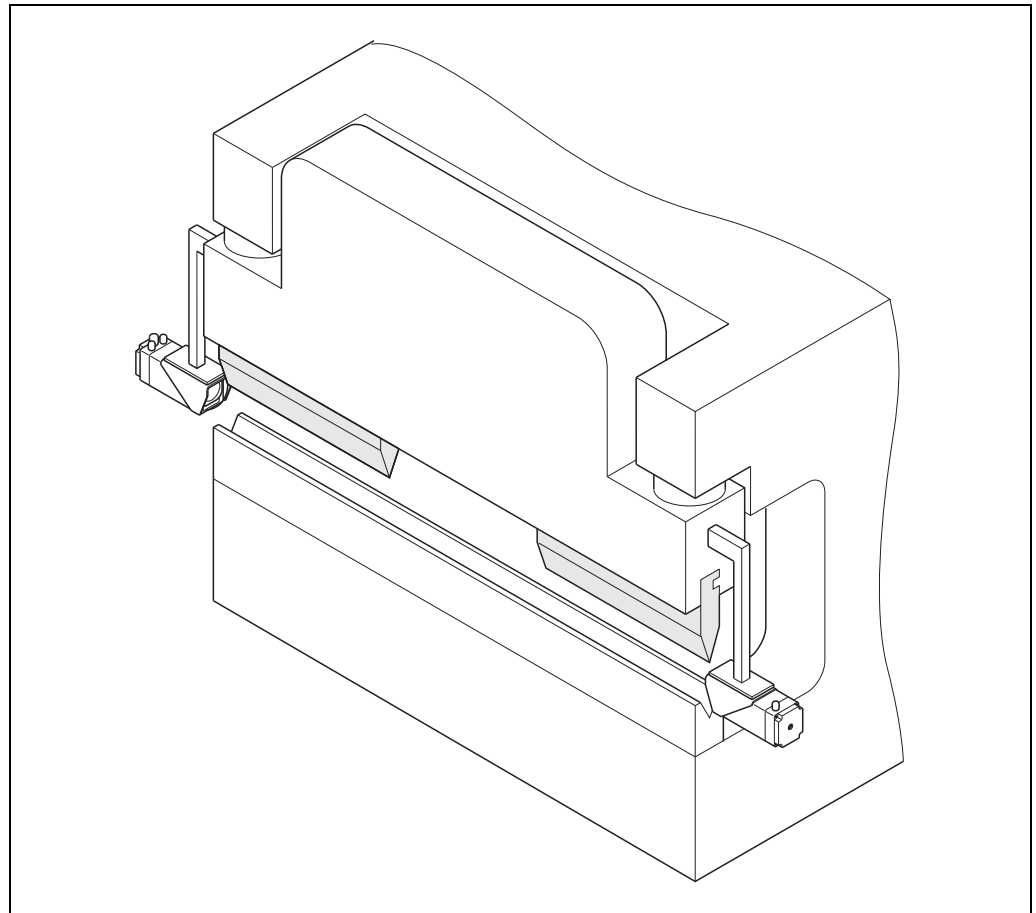
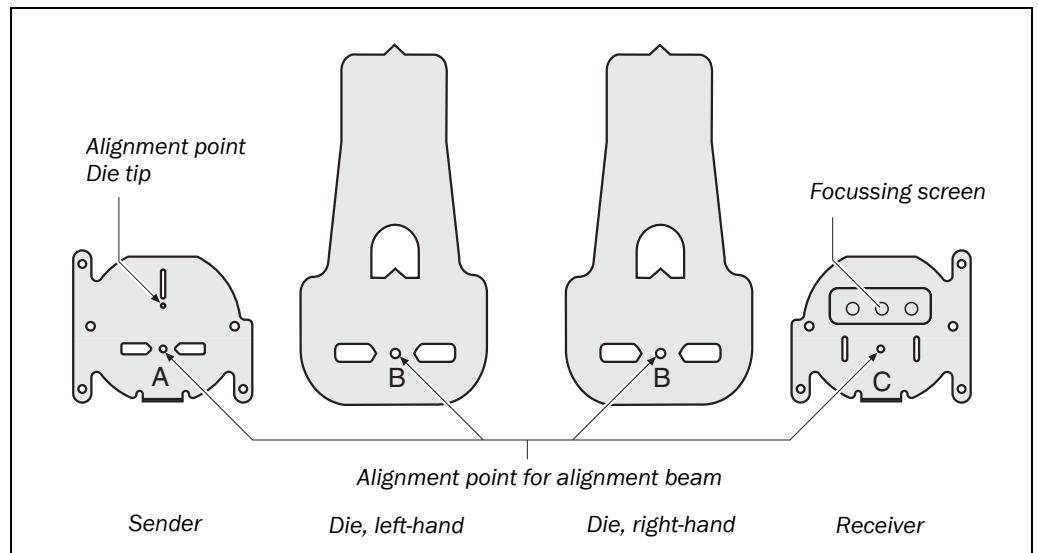

Fig. 37: Alignment masks



Notes Four alignment masks and the values appearing on the 7-segment display will help you align the sender and receiver.

The alignment beam must in each case pass through the hole (alignment point) in the masks.

V 4000 PB

The sender and receiver can be adjusted in four directions.

Fig. 38: Adjustment directions

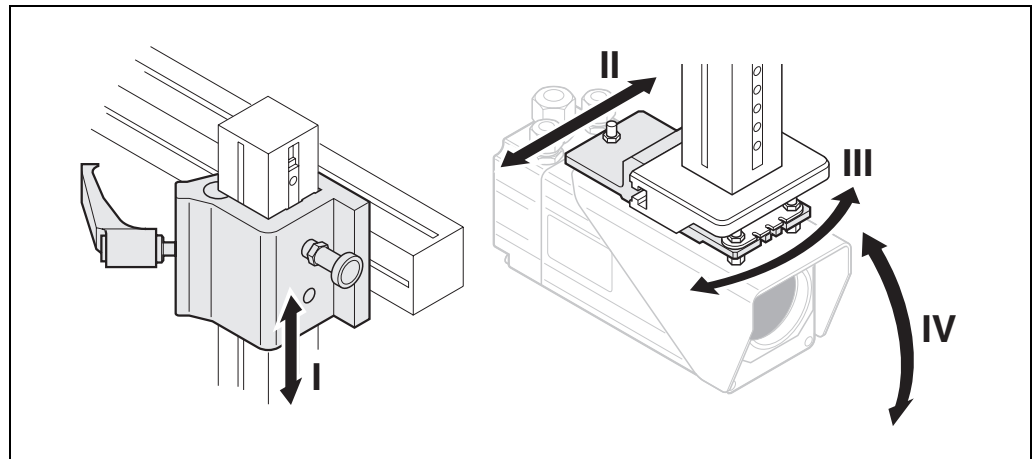

Tab. 16: Adjustment directions

Direction	Meaning
I	Adjustment in the vertical direction on the retaining arm
II	Adjustment in the horizontal direction via the grooved guide in the alignment plate
III	Rotation of the sender on the horizontal plane in the slots of the alignment plate
IV	Rotation of the sender on the vertical plane by adjusting the screw on the rear pin

Alignment of the sender

➤ Use the corresponding operating element to access alignment mode.

Notes If there is no alignment point saved, alignment mode will be requested automatically after switching on.

Fig. 39: Fitting masks A and B

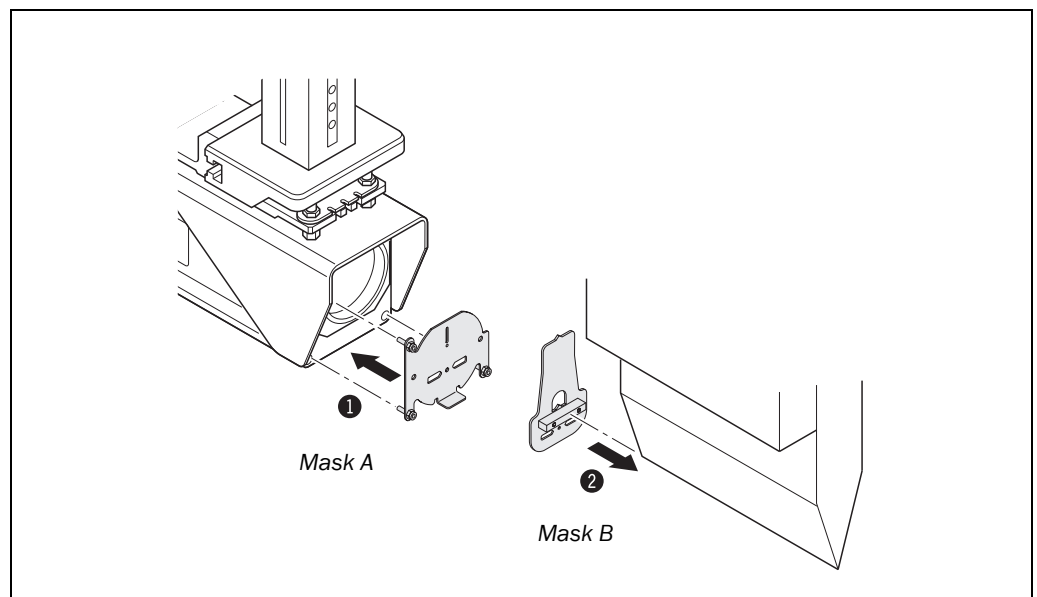

➤ Affix mask **A** in front of the front lens on the sender housing.

➤ On the sender side attach mask **B** to the die. Make sure that the die tip coincides with the bottom edge of the half-moon-shaped cut-out and that it is on the longitudinal axis which is marked on the mask.

Fig. 40: Alignment in directions I and II

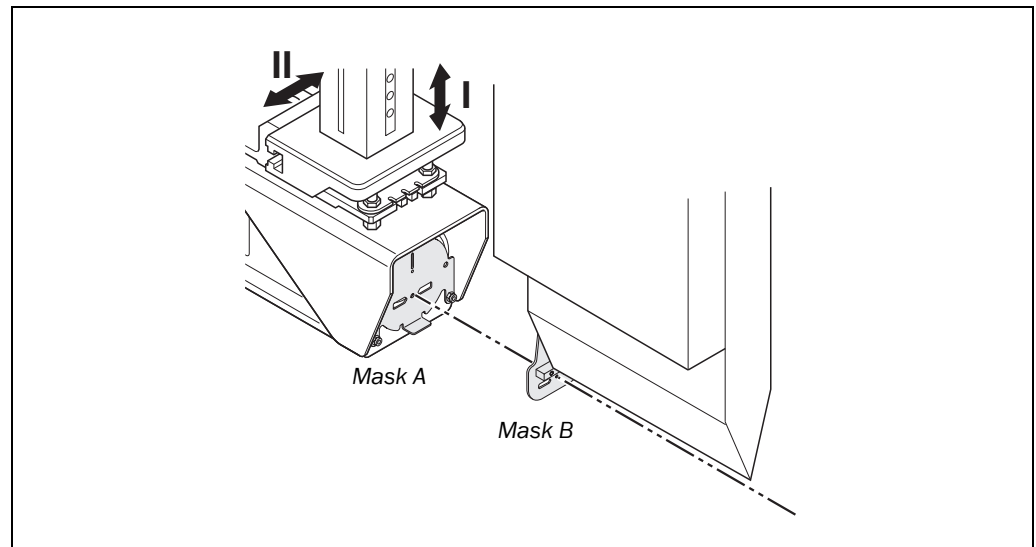

- Move the sender bracket in directions I and II until the alignment beam goes through the hole in mask B.

Fig. 41: Fitting mask B

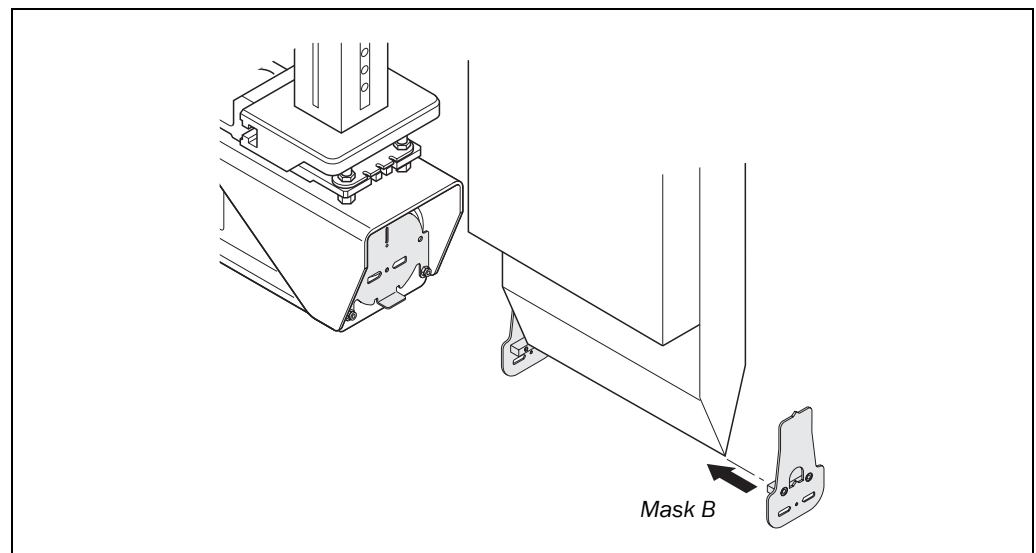

- On the receiver side attach the second mask B to the die. Make sure that the die tip coincides with the bottom edge of the half-moon-shaped cut-out and that it is on the longitudinal axis which is marked on the mask.

V 4000 PB

Fig. 42: Alignment in directions III and IV

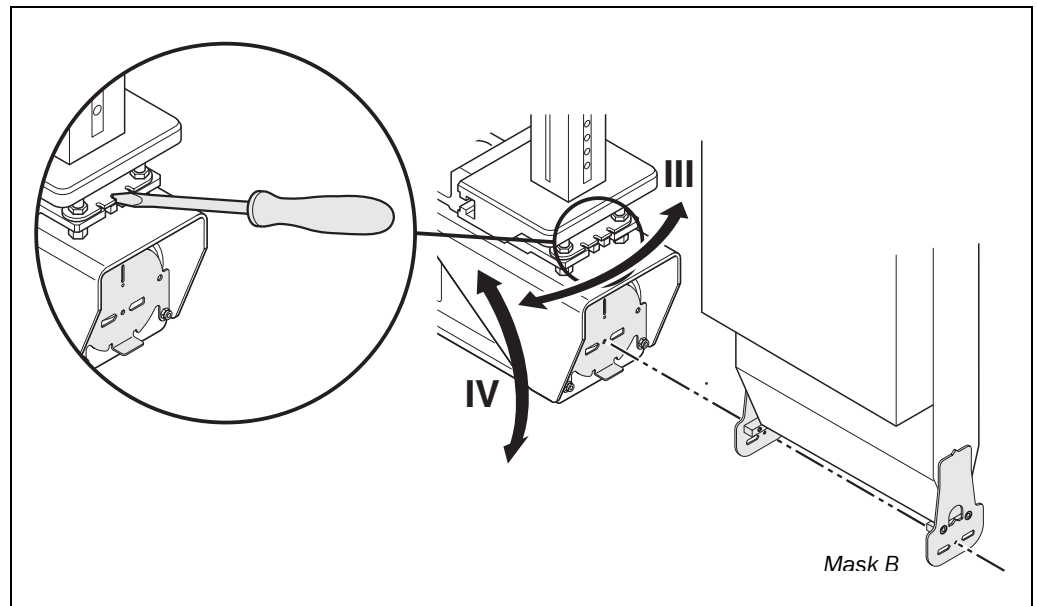

- Move the sender bracket in directions III and IV until the alignment beam goes through the hole of the second mask B.

Adjustment in direction III

With the aid of a steel plate with three notches (auxiliary alignment plate) which is mounted between the front bolts and three notches in the alignment plate, the sender can be rotated on the horizontal plane $\pm 3^\circ$ out of its central position. Here the sender rotates in the slots in the alignment plate – in other words, the sensor is turned on the rear bolts and relative to the alignment plate.

- Notes** When aligning the sender, make sure that the nuts of the bolts on which the alignment plate is mounted are only tightened up handtight. The spring washers will provide the necessary tension.
- Insert the blade of a screwdriver (blade 4) into the middle notch of the alignment plate or steel plate.
 - Turn the screwdriver blade slowly clockwise or anti-clockwise in the middle notch until the alignment beam goes through the hole in the second mask B.
 - You can use the left-hand or right-hand notch to turn the sender even further clockwise or anti-clockwise if this is necessary.
- Notes** Make sure that the alignment beam goes through both B masks. You may need to make realignment adjustments in directions I and II and in directions III and IV.
- Fix the sender brackets in place.

Alignment of the receiver



WARNING

Risk of injury if incorrectly aligned!

Incorrect alignment of the V 4000 PB can result in serious injuries.

- After every alignment operation, carry out a function check.

Fig. 43: Alignment of the receiver

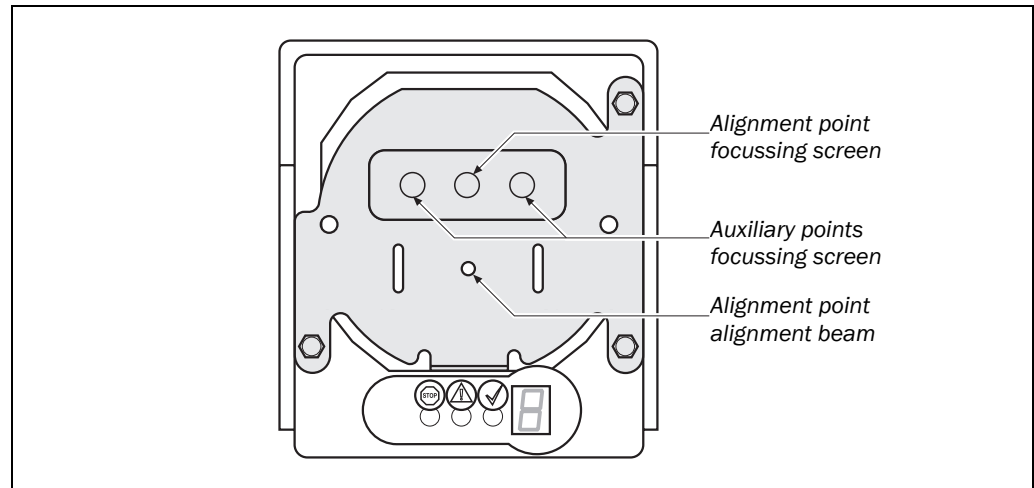

- Affix mask C in front of the front lens on the receiver housing.
- Move the receiver bracket in directions I and II until the alignment beam goes through the hole in the mask.
- Move the receiver bracket in directions III and IV until the three target points (alignment point and two auxiliary points) coincide with the collecting zone on the focussing screen.
- Use the 7-segment display to carry out fine alignment.

Notes

The CDS provides a graphic representation of the alignment state of the receiver. You can also carry out fine alignment with the aid of the CDS display.

Tab. 17: Display during alignment of sender and receiver

Display	Meaning	Action
	Image detector not illuminated	<ul style="list-style-type: none"> ➤ Check the connection of the sender. ➤ Check the rough alignment of the sender and receiver and correct if necessary. ➤ Check the masks. They may have been mixed up or fitted at an angle.
	Invalid pattern	<ul style="list-style-type: none"> ➤ Move the sender bracket in directions I and II until the alignment point is in the target zone.
	Alignment point or all points on left outside the target zone	
	Alignment point or all points above the target zone	
	Alignment point or all points on right above the target zone	
	Alignment point or all points on left above the target zone	
	Alignment point or all points on right outside the target zone	

V 4000 PB

Display	Meaning	Action
	Alignment point or all points below the target zone	➤ Move the sender bracket in directions I and II until the alignment point is in the target zone.
	Alignment point or all points on left below the target zone	
	Alignment point or all points on right below the target zone	
	Alignment point in the target zone, position of the auxiliary points at alignment point out of tolerance (clockwise rotation)	➤ Move the sender bracket in directions III and IV until the alignment point is in the target zone and the auxiliary points in tolerance.
	Alignment point in the target zone, position of the auxiliary points at alignment point out of tolerance (anti-clockwise rotation)	
	Alignment point or all points horizontally outside tolerance	
	Distance between the auxiliary points outside tolerance	➤ Check the masks. ➤ Replace the device (internal mis-justment).
	An attempt has been made to save an invalid alignment point.	➤ Cancel the "Save alignment point" request and continue with alignment.
	Alignment point in the target range, auxiliary points in tolerance	➤ For at least 1 second request alignment mode in order to save the alignment point.

➤ Once the sender and receiver are in the right position (7-segment display) fasten down the receiver brackets.

➤ For at least one second request alignment mode.

The alignment point will be saved.

When the request for alignment mode is cancelled, the V 4000 PB will be reset.

When the self-test (system initialisation) is completed, the V 4000 PB calls for a power-up cycle.

➤ Remove all masks.

➤ Press the teach-in button.

The request for the power-up cycle is acknowledged and the cycle carried out (see Section 8.4 "Carrying out a power-up cycle").

➤ Carry out the function check using the test piece (see Section 7.3 "Function check").

7.2.2 Alignment following a tooling change

Notes Alignment will have to be readjusted following a tool change.

Recommendation If you are working with only 2 or 3 dies of different lengths, it is worth setting up latching marks (defined, vertical bracket positions or markings on the bracket).

How to prepare for alignment following a tool change:

- Ensure that sender and receiver are correctly aligned at first alignment.
- Switch on the power supply to the V 4000 PB.

Tracking without latching marks (checking and initial setting-up of latching marks)



WARNING

Risk of injury if incorrectly aligned!

Incorrect alignment of the V 4000 PB can result in serious injuries.

- After every alignment operation, carry out a function check.

Fig. 44: Tracking without latching marks

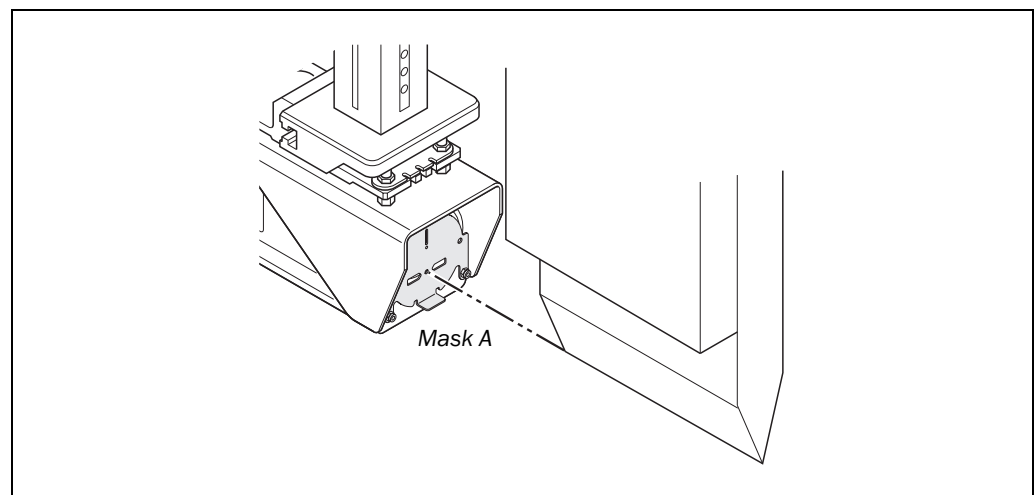

- Press the alignment mode button (signal for alignment mode).
- Affix mask **A** in front of the front lens on the sender housing.
- Move the sender bracket in direction I until the die tip alignment point is intersected by the lower edge of the die.
- Move the receiver bracket in direction I until the correct position is confirmed via the 7-segment display (alignment tolerance ± 6 mm).
- Once the sender and receiver are in the right position (7-segment display ) , hold down the button for alignment mode for at least one second.

The alignment point will be saved.

When the signal for alignment mode is cancelled, the V 4000 PB will be reset.

When the self-test (system initialisation) is completed, the V 4000 PB calls for a power-up cycle.

- Remove mask **A**.
- Press the power-up cycle button.

The request for the power-up cycle is acknowledged and the cycle carried out (see Section 8.4 "Carrying out a power-up cycle").

- Carry out the function check using the test piece (see Section 7.3 "Function check").

V 4000 PB**Tracking with latching marks**

WARNING

Risk of injury if incorrectly aligned!

Incorrect alignment of the V 4000 PB can result in serious injuries.

➤ After every alignment operation, carry out a function check.

➤ Align the sender and receiver on the brackets (manufacturer's brackets) vertically, that is, in direction I.

➤ Carry out the function check using the test piece (see Section 7.3 "Function check").

➤ Initiate a reset by pressing the alignment and teach-in buttons simultaneously.

When the self-test (system initialisation) is completed, the V 4000 PB calls for a power-up cycle.

➤ Press the power-up cycle button.

The request for the power-up cycle is acknowledged and the cycle carried out (see Section 8.4 "Carrying out a power-up cycle").

➤ Carry out the function check using the test piece (see Section 7.3 "Function check").

7.3 Function check

During the function check the following aspects are checked:

- Protective function with the test rod (objects larger than 14 mm)
- Distance from the tool
- Emergency stop properties
- Overall machine overrun

Fig. 45: Test piece

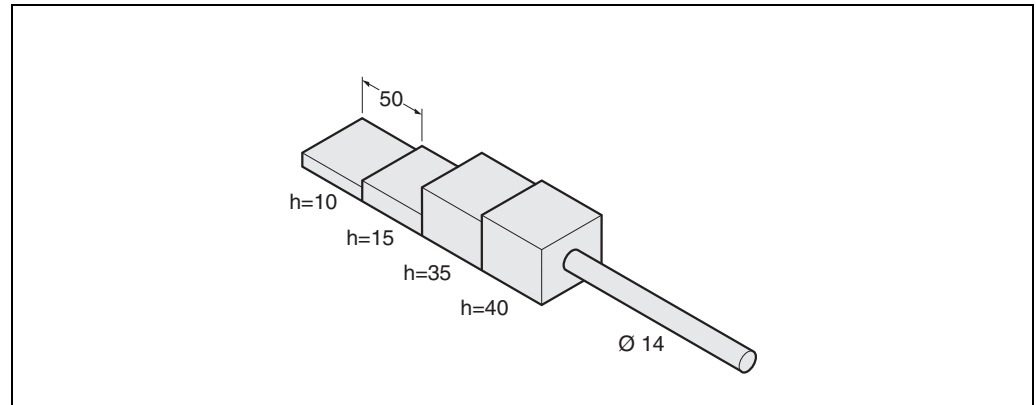

How to prepare for the function check:

- Ensure that the press is fitted with a die which extends for its full working length.
- Ensure that sender and receiver have been correctly aligned at first alignment.
- Switch on the power supply to the V 4000 PB.
- Select standard mode (see Section 8.2 "Selecting protective volume mode").
- Carry out a power-up cycle (see Section 8.4 "Carrying out a power-up cycle").

V 4000 PB**Function check with the test rod (handle of the test piece)**

Fig. 46: Function check with test rod

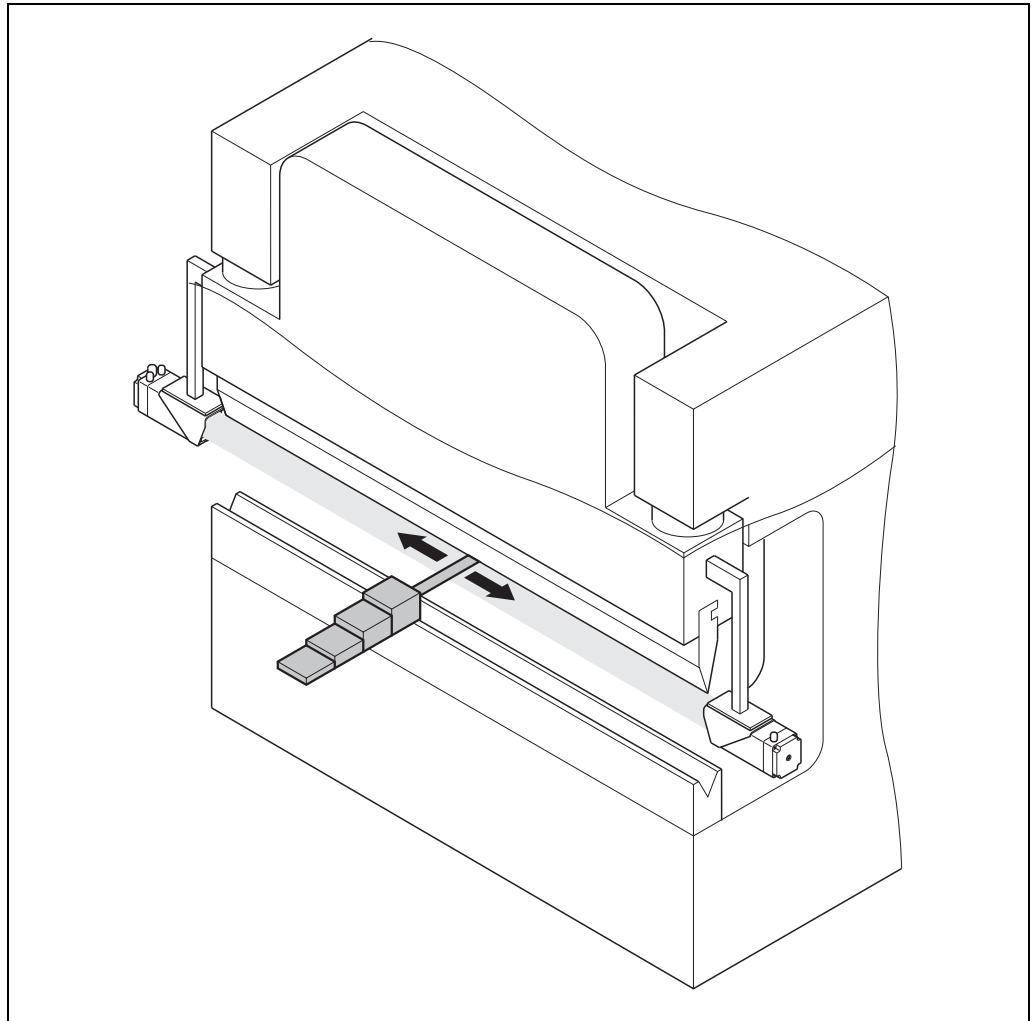

- Slowly pass the rod (the handle of the test piece) along the die tip for the full extent of the protective volume.

The rod must be detected over the whole extent of the protective volume beneath the die tip.

During this test, the red LED on the receiver must stay on the whole time.

Function check with the test piece

Notes The pinch point must be known from teach-in.

Fig. 47: Function check with test piece (10 mm)

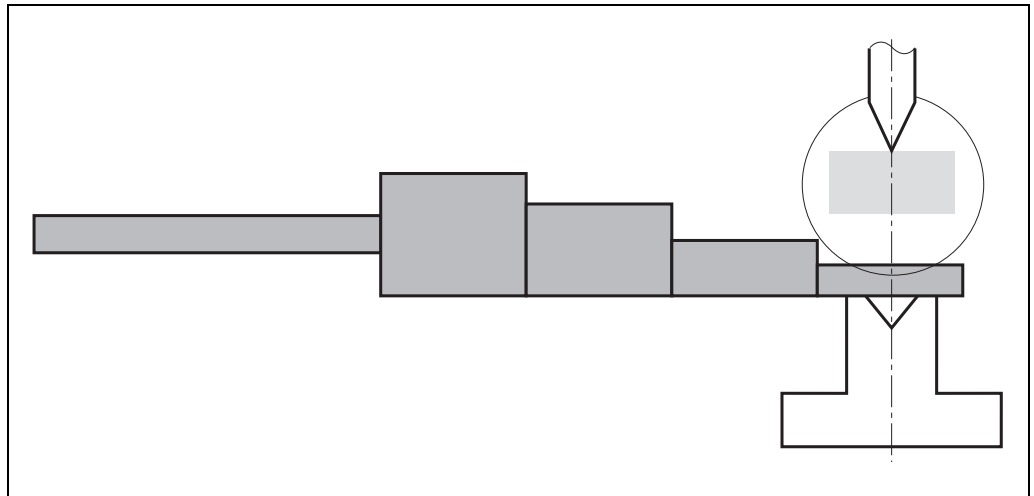

- Place the section of the test piece having a height of 10 mm on the female die or on the workpiece so that the section lies in the middle of the pressure axis.
- Start the closing movement with the maximum closing speed.

The protective volume is interrupted by the test piece and the closing movement stopped by the OFF state of the V 4000 PB.

After the closing movement has stopped, the die tip must not be touching the test piece.

Fig. 48: Function check with test piece (15 mm)

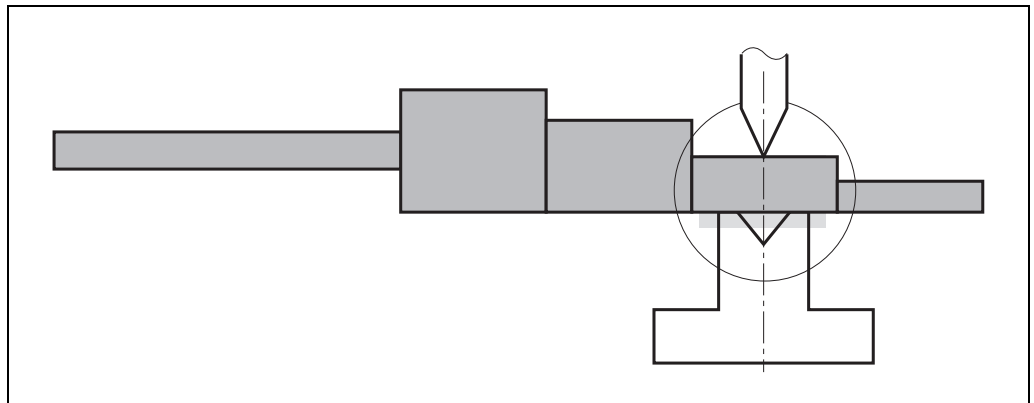

It must then be possible to push the following section (having a height of 15 mm) into the remaining gap.

- Check whether the following section having a height of 15 mm can be pushed into the remaining gap.
- Carry out the test on the outer left- and outer right-hand side and in the centre of the press.
- Repeat the test with the 35mm-high section (40 mm for checking the gap).

7.4 Regular checks of the protective device by specialist personnel

Regular checks will ensure that any changes to the machine or manipulation of the protective device after commissioning are detected.

- Check the system at the inspection intervals specified in the national rules and regulations.
- If major modifications have been made to the machine or the protective device, or if the V 4000 PB has been modified or repaired, the system must be checked again as specified in the checklist in the annex (see Section 13.3 Manufacturer's checklist).

Tab. 18: Regular checks

Check	Daily	Annually	Following a tool change	Following configuration
Alignment		x	x	x
Protective function with test rod	x	x	x	x
Emergency stop properties of the entire system	x	x	x	x
Overall machine overrun		x		
Configuration data		x		x
Number of repetitions	1	10	1	10

7.5 Daily checks of the protective device by authorised commissioned persons

The effectiveness of the protective device must be checked daily or prior to the start of work by a specialist or by authorised commissioned persons, using the correct test rod. The check must furthermore be carried out at each tool change.



WARNING

Do not operate the machine if errors or faults are found during the checks!

If any of the following conditions is not fulfilled, no work may be carried out at the machine.

- In this case have the installation of the V 4000 Press Brake checked by specialist personnel.

Visual inspection of the protective device

- Check the protective device (mounting, housing, electrical connection, optics) for damage or wear.
- Switch the machine on and check whether at least one LED at the receiver of the V 4000 Press Brake (LED below the receiver lens) lights up permanently.

Checking the protective volume

- Check whether the red LED at the receiver of the V 4000 Press Brake lights up when the protective volume is interrupted with the test rod (handle of the test piece) below the die tip. Carry out the test along the entire protective volume below the die tip.
- Carry out a power-up cycle using a workpiece.

- Carry out the following test **on the left and right side of the female die and in the centre of the female die.**
 - Place the section of the test piece having a height of 10 mm on the workpiece so that the section lies in the middle of the pressure axis.
 - Start the closing movement with the maximum closing speed.
 - After the press has stopped, check whether the following section having a height of 15 mm can be pushed into the remaining gap.
- Repeat the test with the section of the test piece having a height of 35 mm and check whether the following section having a height of 40 mm can be pushed into the remaining gap after the press has stopped. Also carry out this test **on the left and right side of the female die and in the centre of the female die.**

8 Operation



WARNING

Nuisance shutdowns due to air contamination!

The functioning of the V 4000 PB can be affected by air contamination and nuisance shutdowns may be the result.

- Keep the area around the V 4000 PB free of smoke, fumes, steam and other types of air contamination (particularly contamination of the lenses, such as by oil).

How to prepare for operation:

- Carry out the daily check (see Section 7.5 "Daily checks of the protective device by authorised commissioned persons").

8.1 Switching the machine on

Display sequence during switch-on

After the system is switched on, the sender and receiver carry out a self-test (system initialisation). The 7-segment display indicates the device status during the self-test.

The display values have the following meaning:

Tab. 19: Displays during the power-up cycle

Display	Meaning
-	Switch on. This is followed by the self-test of the V 4000 PB.
	Testing the 7-segment display. All segments are activated sequentially.
E	It has not (yet) been possible to complete the self-test successfully.
4	The input states do not (yet) correspond to the values expected.
E	V 4000 PB requires configuration.
Other display	<ul style="list-style-type: none"> • Protective volume mode: see Section 8.2 "Selecting protective volume mode" • Device error: see Section 9.3 "Error displays of the 7-segment display"

8.2 Selecting protective volume mode

- Use the selector switch to select protective volume mode (standard, box or back-stop mode).

Depending on which protective volume mode you have selected you will see the following displays on the 7-segment display:

Tab. 20: Protective volume mode displays

Display	Meaning
	Standard mode
	Box mode
	Back-stop mode

- If the selector switch is pointing to box or back-stop, switch the selector switch to standard protective volume mode first and then to the protective volume mode you want.

Note The protective volume mode you have selected will be available thereafter with every start signal.

In the case of the box or back-stop protective volume modes, the start signal for the closing movement must be given twice (by double-clicking). The operator will then be warned that the machine is working in a special mode in which there is only limited protection due to a reduction in the protective volume.

8.3 Resetting

A V 4000 PB reset corresponds to a switch-on. After the reset, there will be a self-test and a power-up cycle.

- Make a reset by pressing simultaneously the buttons for alignment mode and for teach-in.

8.4 Carrying out a power-up cycle

Following machine switch-on and system initialisation the V 4000 PB requests teach-in mode. A power-up cycle will be requested if the V 4000 PB has, during operation, detected a time-out since the last power-up cycle, or the V 4000 PB has been reset.

The power-up cycle cannot be carried out unless the standard protective volume mode has been previously selected, if only for a brief period. After this the power-up cycle can be carried out in any protective volume mode.

Tab. 21: Carrying out a power-up cycle, for example in standard mode

Action	Result	LED display
➤ If necessary, open the press.	The press is open.	● Red ● Yellow (90/10)
➤ Press the teach-in button.	The request for the power-up cycle is acknowledged.	● Green
➤ Insert the workpiece.	–	● Green

V 4000 PB

Action	Result	LED display
➤ Press the foot switch (start signal for the closing movement).	<ul style="list-style-type: none"> • The press closes at high closing speed. • The V 4000 PB switches the OSSDs off. • The high closing speed is stopped. • The overall machine overrun is checked. 	<ul style="list-style-type: none"> ● Green ● Red
➤ Release the foot switch (this cancels the start signal).	–	● Green
➤ Press the foot switch again (start signal for the closing movement).	<ul style="list-style-type: none"> • The V 4000 PB requests the target speed from the press controller. • The press controller starts the braking procedure. • The V 4000 PB detects and accepts the target speed. • The braking distance is determined once the target speed has been reached. • The V 4000 PB cancels the request for target speed. • The press controller can accelerate up to the high closing speed. • The workpiece interrupts the protective volume. • The press stops. • The pinch point is determined. • The overall machine overrun is checked. 	<ul style="list-style-type: none"> ● Green ● Red
➤ Release the foot switch (this cancels the start signal).		● Green
➤ Press the foot switch again (start signal for the closing movement).	The press finishes the operating cycle.	● Green
➤ Carry out the function check (see Section 7.3).	The press is now ready for operation.	● Green

8.5 Carrying out teach-in

Note From the pinch point the V 4000 PB calculates all safety-relevant parameters (switch-over point and muting point). For this reason the safety-relevant parameters cease to apply after a change of material.

➤ This means you should carry out teach-in every time a material is changed.

Teach-in cannot be carried out unless the standard protective volume mode has been previously selected. Once this has been done, teach-in can be carried out in any protective volume mode.

Recommendation If the V 4000 PB does not detect the pinch point or does so only after a repeated request for teach-in, use the magnetic plate supplied to cover the female die opening beneath the workpiece.

The magnetic plate should be flush with the top surface of the female die. It must not project above the level of the workpiece surface.

Tab. 22: Carrying out teach-in, for example in standard mode

Action	Result	LED display
➤ Select standard protective volume mode.	–	
➤ Press the teach-in button.	–	
➤ If necessary, open the press.	The press is open.	● Green
➤ Insert the workpiece.	–	● Green
➤ Press the foot switch (start signal for the closing movement).	<ul style="list-style-type: none"> • The press controller accelerates up to the high closing speed. • The workpiece interrupts the protective volume. • The press stops. • The pinch point is determined. • The overall machine overrun is checked. 	<ul style="list-style-type: none"> ● Green ● Red
➤ Release the foot switch (this cancels the start signal).		● Green
➤ Press the foot switch again (start signal for the closing movement).	<ul style="list-style-type: none"> • The press finishes the operating cycle. • The press is now ready for operation. 	● Green

8.6 Bending in standard mode

- Select standard protective volume mode (7-segment display .
- If the sheet thickness of the workpiece has changed, carry out teach-in (see Section 8.5 "Carrying out teach-in").
- Insert the workpiece.
- Press the foot switch (start signal for the closing movement).

The press carries out the operating cycle.

8.7 Bending in box mode



WARNING

Catching or crushing of fingers or hands due to partial blanking of the protective volume and also within the tolerance zone at the pressure axis!

Due to partial blanking of the protective volume, objects in the tolerance zone will not be detected.

- Make sure the workpiece is handled correctly (see Section 2.5 "Safety in operation").

- Select box protective volume mode (7-segment display .
- If the sheet thickness of the workpiece has changed, carry out teach-in (see Section 8.5 "Carrying out teach-in").

8.8 Bending in back-stop mode



WARNING

Catching or crushing of fingers or hands due to partial blanking of the protective volume and also within the tolerance zone!

Due to partial blanking of the protective volume, objects in the tolerance zone will not be detected.

- Make sure the workpiece is handled correctly (see Section 2.5 "Safety in operation").

- Select back-stop protective volume mode (7-segment display .
- If the sheet thickness of the workpiece has changed, carry out teach-in (see Section 8.5 "Carrying out teach-in").

8.9 Changing the sheet thickness

If the sheet thickness of the workpiece changes you will need to carry out teach-in again (see Section 8.5 "Carrying out teach-in").

8.10 Tool changing

Following a tool change, the following steps are necessary:

- Alignment following a tool change (see Section 7.2.2)
- Standard protective volume mode (see Section 8.2)
- Carrying out a power-up cycle (see Section 8.4)
- Function check with the test piece (see Section 7.3)

8.11 Care and maintenance



WARNING

Hazardous radiation exposure by the laser beam during disassembling!

The V 4000 PB is maintenance-free. The V 4000 PB does not contain any repairable components.

- Do not attempt to disassemble the V 4000 PB for repair.
- Return a defective unit to the manufacturer.

Notes

The front lenses of the sender and receiver should not be cleaned unless they are dirty. To avoid damage to the V 4000 PB do not use aggressive or abrasive cleaning agents.

Cleaning the front lenses:

- Use a clean brush to remove dust from the front lens.
- Spray the lens with glass cleaning liquid containing alcohol so that the front lens is wetted but no droplets form on the lens.
- To remove hard particles of grit or the like from the lens, carefully dab away the liquid with the SICK lens cloth (SICK part no. 4 003 353).
- Spray the front lens again and with a dry part of the cloth wipe off the lens. Do not apply pressure to remove the liquid since hard particles could then scratch the lens.
- After cleaning, check the positions of the sender and receiver to ensure the safety function of the sensor is still present. If necessary, re-align the sender and receiver (see Section 7.2 "Aligning sender and receiver").
- Carry out a function check (see Section 7.3 "Function check").

9 Diagnostics

This chapter describes how to identify and remedy errors and malfunctions of the V 4000 PB.

9.1 Response to errors and malfunctions



Cease operation if there is malfunctioning or other operational problems!

- Stop the machine if you cannot clearly identify or allocate the error and if you cannot safely remedy the malfunction.

Lock-out state

With certain errors or an erroneous configuration, the system can go into the lock-out state.

To put the device back into operation, carry out the following steps:

- Correct the source of the problem as described in Section 9.2 "Error displays of the LEDs" and 9.3 "Error displays of the 7-segment display".
- Switch the V 4000 PB power supply off and back on again:
 - Either make a reset by pressing simultaneously the buttons for alignment mode and for teach-in.
 - Or switch the machine off and back on again.

9.2 Error displays of the LEDs

This section explains what the LED error displays mean and how you can respond.

Error displays of the sender LED

Tab. 23: Error displays of the sender LED

Display	Possible cause	Remedying the error
○ Yellow	No operating voltage, or voltage too low.	➤ Check the voltage supply and switch it on if necessary.

Error displays of the receiver LEDs

Tab. 24: Error displays of the receiver LEDs

Display	Possible cause	Remedying the error
○ Red and ○ Green	The bypass function has been selected.	➤ Check to see whether the bypass function has been selected (configuration). ➤ Check whether there is adequate operating voltage











9.3 Error displays of the 7-segment display

This section explains the meaning of the error displays of the 7-segment display and how you can respond.

Tab. 25: Error displays of the 7-segment display

Display	Possible cause	Remedying the error
	Erroneous input signals	➤ Check the input signals, foot switch and the protective volume mode selector switch.
	Configuration incomplete	The display goes off automatically once the configuration has been successfully transferred. If the does not disappear: ➤ Check the configuration of the system using the CDS (Configuration & Diagnostic Software). ➤ Re-transfer the corrected configuration to the system.
	EDM error (switch-on)	➤ Check the contactors and their wiring, eliminate any wiring errors, if necessary. ➤ Check the voltage level at the EDM input. ➤ Check to see whether the EDM configuration is correct.
	EDM error	➤ Check the contactors and their wiring, eliminate any wiring errors, if necessary. ➤ Check the voltage level at the EDM input. ➤ Check to see whether the EDM configuration is correct. ➤ Due to an EDM error, the device is in the lock-out state. Carry out a reset.
	System error	➤ Have the receiver replaced.
	Overcurrent at switching output 1	➤ Check the contactor. Replace, if necessary. ➤ Check the wiring for a short-circuit to 0 V.
	Short-circuit at switching output 1	➤ Check the wiring for a short-circuit to 24 V.
	Short-circuit at switching output 1	➤ Check the wiring for a short-circuit to 0 V.
	Overcurrent at switching output 2	➤ Check the contactor. Replace, if necessary. ➤ Check the wiring for a short-circuit to 0 V.
	Short-circuit at switching output 2	➤ Check the wiring for a short-circuit to 24 V.
	Short-circuit at switching output 2	➤ Check the wiring for a short-circuit to 0 V.
	Short-circuit between switching outputs 1 and 2	➤ Check the wiring and rectify the error.
	Internal error	➤ Check the OSSD load. ➤ Have the receiver replaced.

V 4000 PB

Display	Possible cause	Remedying the error
	Discrepancy time is longer than configured	➤ Re-configure the discrepancy time accordingly.
	No protective volume mode selected, or several	<ul style="list-style-type: none"> ➤ Check the connection and the function of the protective volume mode selector switch. ➤ Re-configure the discrepancy time accordingly. ➤ Check for a short-circuit in the connection of the selector switch on the switching amplifier.
	Bypass input signals are implausible	<p>This message cannot appear unless the bypass has been activated in the configuration.</p> <ul style="list-style-type: none"> ➤ Check the bypass wiring, eliminating any wiring errors or short-circuits, if necessary.
	Incremental encoder signal is implausible	<ul style="list-style-type: none"> ➤ Check the configuration. ➤ Check the incremental encoder. ➤ Check the wiring.
	Dazzle	<ul style="list-style-type: none"> ➤ Cut out outside light from an external light source, if necessary. ➤ Check the wiring from the sender or receiver, eliminating any wiring errors, if necessary.
	The maximum closing speed taught in during the power-up cycle has been exceeded	➤ Carry out a power-up cycle.
	The maximum closing speed specified in the configuration has been exceeded	<ul style="list-style-type: none"> ➤ Reconfigure the maximum closing speed accordingly. ➤ Check to see whether the incremental encoder signals have got mixed up, eliminating the wiring error, if necessary. <p>There may be a error in the press brake (see press brake operating instructions).</p>
	The overall machine overrun specified in the configuration has been exceeded	<ul style="list-style-type: none"> ➤ Reconfigure the overall machine overrun accordingly. ➤ Check to see whether the incremental encoder signals have got mixed up, eliminating the wiring error, if necessary. <p>There may be an error in the press brake (see press brake operating instructions).</p>
	<p>The press is closing although the foot switch has not been operated</p> <p>The press is closing although the OSSDs have been deactivated</p>	There may be an error in the press brake (see press brake operating instructions).
	Invalid configuration of the EDM	➤ Verify that the machine-side EDM is connected.

Display	Possible cause	Remedying the error
	Under or over-voltage in the 24 V voltage supply	➤ Check the voltage supply.

Notes If you cannot remedy an error with the aid of the LED or 7-segment display error displays, you can carry out extended diagnostics via the CDS or you can contact your local SICK branch.

9.4 Extended diagnostics via CDS



The CDS software supplied with the device (Configuration & Diagnostic Software) includes extended diagnostics options. If you cannot identify what kind of error is occurring or if you have serviceability problems, the CDS allows you to locate the error more accurately. Detailed information to be found

- in the on-line help function of the CDS (Configuration & Diagnostic Software)
- in the user manual for the CDS

Conduct extended diagnostics of the V 4000 PB as follows:



- Connect the PC or notebook in which CDS has been installed to the receiver of the V 4000 PB.
- Carry out diagnostics at the V 4000 PB receiver.
Device symbol V 4000 PB, **Receiver**, context menu **Diagnostics, Show**.

9.5 SICK support

If you cannot correct an error using the information in this section, please contact your local SICK branch.

Write the branch's telephone number in the box below so it is readily accessible to you or anyone else. The telephone number is given on the last page of these operating instructions.

Telephone number of your SICK branch

Notes Following repair work by SICK you will find that the configuration of your V 4000 PB will have been reset to its original state.

➤ Back your configuration up to a separate data medium first.

10 Technical data

10.1 Device data sheet

10.1.1 V 4000 PB technical data

General specifications

Tab. 26: V 4000 PB general specifications

	Minimum	Typical	Maximum
Laser protection class	Laser class 1M (21 CFR 1040.10 and 1040.11, IEC 60825-1:2001)		
Enclosure rating	IP 54 (EN 60529)		
Protection class according to DIN VDE 0106, DIN EN 50178	III		
Type according to IEC 61496	4		
Operating temperature range	0 °C		+50 °C
Storage temperature range	-25 °C		+70 °C max. 24 h
Humidity (taking operating temperature range into account)	IEC/EN 61496-1, Sections 5.1.2 and 5.4.2		
Air humidity (non-condensing)	15 %		95 %
Vibrations	IEC/EN 61496-1, Sections 5.1.2 and 5.4.4.1		
Frequency range	10 Hz		100 Hz
Tuning	1 octave/min		
Amplitude	0.35 mm or. 5 g		
Number of attempts	20 per axis, 3 axes without dwell time at resonant frequencies		
Shock resistance			
Individual shock	15 g, 11 ms according to EN 60068-2-27		
Repetitive shock	10 g, 16 ms according to IEC/EN 61496-1, Sections 5.1.2 and 5.4.4.2		

V 4000 PB

Tab. 27: V 4000 PB general specifications (cont'd)

	Minimum	Typical	Maximum
Sender	Pulsed laser diode		
Wavelength		635 nm	
Divergence of collimated beam		0.1 mrad	
Pulse output power		5 mW	
Light exit surface		Ø 58 mm	
Light source	Laser diode		
Laser class	1M		
Type of cable to connect	with braided copper shield		
Surge impedance		100 Ω	
Cable cross-section	0.25 mm ²		0.6 mm ²
Housing			
Material	Aluminium		
Colour	RAL 1021 (rape yellow)		
V 4000 PB dimensions (receiver/sender) ¹⁾			
Height			100 mm
Width			90 mm
Length			250 mm
Total weight for sender or receiver with alignment plate		2.6 kg	

Ambient conditions – explosion protection

No explosion protection is provided for the V 4000 PB. The corresponding conditions do not usually occur with press brakes and the environment where they are used.

Extraneous light

The extraneous light requirements in IEC61496-2 Section 5.4.6 and also the corresponding function tests per IEC IEC61496-1 Section 5.2.3 apply to the V 4000 PB.

¹⁾ Without cable threads projecting when system plug fitted.

General system data

Tab. 28: V 4000 PB general system data

	Minimum	Typical	Maximum
Protective volume height	6 mm	26 mm	
Protective volume width		40 mm	
Resolution	10 mm below		14 mm
Lateral penetration depth required	5 mm ²⁾	▪	
Response time T ₁			10 ms
Stopping distance S			11 mm
Distance between sender and receiver	0 m		7.5 m
Overall machine overrun of the press after OSSD opens (when v _{max} = 300 mm/s)			8 mm
Slow closing speed of the press (v _{slow} ; v ₁₀)			10 mm/s
Maximum closing speed of the press (v _{max})			300 mm/s
Switch-on time		3 s	5 s

Tab. 29: V 4000 PB electrical specifications

Electrical specifications

	Minimum	Typical	Maximum
Electrical connection	Plug-in adapter box with screw-terminal connections		
Screw terminal technical data			
Cross-section of flexible wire ³⁾	0.14 mm ²		1.0 mm ²
American Wire Gauge (AWG)	26		16
Stripped length of wire		5 mm	
Screw tightening torque	0.22 Nm		0.25 Nm
Cable length with power supply tolerance of ±20%			
With cable cross-section 0.34 mm ²			20 m
Cable length with power supply tolerance of ±10%			
With cable cross-section 0.34 mm ²			25 m
Cable length with power supply tolerance of ±5%			
With cable cross-section 0.34 mm ²			30 m

²⁾ + 6.6 mm in box or back-stop mode with protective volume on operator side

³⁾ Wire end ferrules are not required

V 4000 PB

Tab. 30: V 4000 PB electrical specifications (cont'd)

	Minimum	Typical	Maximum
Supply voltage (SELV) The external voltage supply must be capable of buffering brief mains failures of 20 ms as specified in EN 60 204. Suitable power supplies are available as accessories from SICK (Siemens series 6 EP 1).	19.2 V	24 V	28.8 V
Permissible residual ripple			±5 %
Starting current ⁴⁾			0.5 A
Operating current at 24 V without fan-out			0.2 A
Operating current with maximum fan-out			2 A
Power consumption without fan-out			5 W
Power consumption with maximum fan-out			45 W
Digital control inputs for input devices – Teach-in – Alignment – Protective volume mode selector switch – EDM			
Input resistance at HIGH		2 kΩ	
Voltage for HIGH	11 V	24 V	28.8 V
Voltage for LOW	-3 V	0 V	5 V
Input capacitance		100 nF	
Static input current	4 mA		15 mA
Digital control input pairs for input devices – Start / start (complementary) – Bypass / bypass (complementary)			
Input resistance at HIGH		2 kΩ	
Voltage for HIGH	11 V	24 V	28.8 V
Voltage for LOW	-3 V	0 V	5 V
Input capacitance		100 nF	
Static input current	4 mA		15 mA

⁴⁾ Starting currents of the input capacitors are not taken into account.

Tab. 31: V 4000 PB electrical specifications (cont'd)

	Minimum	Typical	Maximum
OSSDs			
Switching output pairs	2 PNP semiconductors, short-circuit protected ⁵⁾ , cross-circuit monitored		
Switching voltage ON state at 500 mA	$U_V - 2.7 \text{ V}$		U_V
Switching voltage OFF state	0 V	0 V	3.5 V
Source switching current	6 mA	0.2 A	0.5 A
Leakage current ⁶⁾			250 μA
Load inductance ⁷⁾			2.2 H
Load capacity			2.2 μF at 50 Ω
Switching sequence (without switchover)	Depends on load inductance		
Permissible line resistance ⁸⁾			2.5 Ω
Test pulse width ⁹⁾		150 μs	200 μs
Test frequency	80 ms	100 ms	120 ms
Minimum configurable switch-off time of the OSSDs	100 ms	100 ms	1000 ms
Skew with switching on OSSDs between OSSD2 and OSSD1		2 ms	10 ms
Signalling outputs for			
- Teach-in request			
- Request for target speed v_{slow}			
Switching voltage HIGH at 200 mA	$U_V - 3.3 \text{ V}$		U_V
Source switching current			200 mA
Current limiting (after 5 ms at 25 °C)	400 mA		500 mA
ON delay		1.4 ms	2 ms
OFF delay		0.7 ms	2 ms

⁵⁾ Applies to voltages in the range between U_V and 0 V.

⁶⁾ In the event of a fault (interruption of the 0 V line), the leakage current flows maximally in the OSSD line. The downstream control element must identify this condition as LOW. An EPLC (error-proof programmable logic controller) must identify this condition.

⁷⁾ The maximum rated load inductance is higher with lower switching sequence.

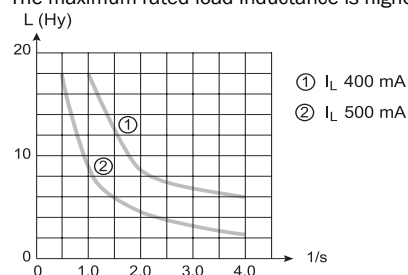

⁸⁾ Make sure you limit the individual line core resistance to the downstream control element to this value to ensure that a short-circuit between the outputs is sure to be detected. (In addition, note EN 60 204-1)

⁹⁾ When active, the outputs are tested cyclically (brief LOW). When selecting the downstream control elements, make sure that the test pulses do not result in deactivation.

V 4000 PB

Tab. 32: V 4000 PB electrical specifications (cont'd)

	Minimum	Typical	Maximum
Configuration and diagnostics interface			
Interface type	RS232 (proprietary)		
Transfer speed	9600 baud 19200 baud 38400 baud 57600 baud		
Cable length at 9600 baud and 0.25 mm ² cables			15 m
Galvanised decoupling	No		
Output TxD HIGH	5 V		15 V
Output TxD LOW	-15 V		-5 V
Voltage range RxD	-15 V		15 V
Operating point RxD LOW	-15 V		0.4 V
Operating point RxD HIGH	2.4 V		15 V
Short-circuit current at TxD	-60 mA		60 mA
Maximum voltage level at RxD	-15 V		15 V
Maximum voltage level at TxD	-11 V		11 V
Data interface			
Interface type	RS-422 (proprietary)		
Transfer speed (selectable)	9600 baud 19200 baud 38400 baud 57600 baud		
Cable length at 57.6 kbps and 0.25 mm ² cables			15 m
Galvanised decoupling	Yes		
Differential output voltage at sender (between TxD+ and TxD-) with 50 Ω load	±2 V		±5 V
Differential input threshold at receiver (between RxD+ and RxD-)	±0.2 V		
Short-circuit current at TxD+, TxD-	-30 mA		-150 mA
Maximum voltage level at TxD+, TxD-	-7 V		+7 V
Maximum voltage level at RxD+, RxD-	-7 V		+7 V
Terminating resistor		100 Ω	
Type of cable to connect	Stranded in pairs with braided copper shield		
Surge impedance of the cable to be connected		100 Ω	
Cable cross-section of the cable to be connected	0.25 mm ²		0.6 mm ²

10.1.2 Technical data for PBI (press brake interface)

Tab. 33: PBI technical data

	Minimum	Typical	Maximum
Enclosure rating	IP20		
Supply voltage	19.2 V	24 V	28.8 V
Residual ripple			±5 %
Power consumption			7.5 W
Data interface – input			
Interface type	RS-422		
Galvanised decoupling	No		
Maximum voltage level	-7 V		+7 V
Input current			1 mA
Differential threshold voltage	-200 mV	-125 mV	-50 mV
Input voltage – hysteresis		25 mV	
Terminating resistor		100 Ω	
Pulse frequency			160 kHz
Number of pulses per mm			640
Data interface – output			
Interface type	RS-422		
Galvanised decoupling	No		
Maximum voltage level	-7 V		+7 V
Differential output voltage with 100 Ω load	2 V	3.1 V	
Short-circuit current	-30 mA		-150 mA
Type of cable to connect	Stranded in pairs with braided copper shield		
Surge impedance		100 Ω	
Cable cross-section	0.25 mm ²		0.6 mm ²
Dimensions			
Height			90 mm
Width			45 mm
Depth			130 mm
Total weight		0.1 kg	

V 4000 PB

10.1.3 Incremental encoder technical data

Tab. 34: Technical data of decodable incremental encoders

	Minimum	Typical	Maximum
Decodable incremental encoder	Two-channel encoder with 90° phase shift		
Incremental encoder outputs required	Digital (RS-422)		
Galvanised decoupling	No		
Maximum voltage level	-7 V		+7 V
Pulse frequency			75 kHz
Terminating resistor		100 Ω	
Number of pulses per mm	45	50	300
Cable length (shielded)			10 m

10.2 Dimensional drawings

10.2.1 Sender and receiver

Fig. 49: Dimensional drawings: sender and receiver

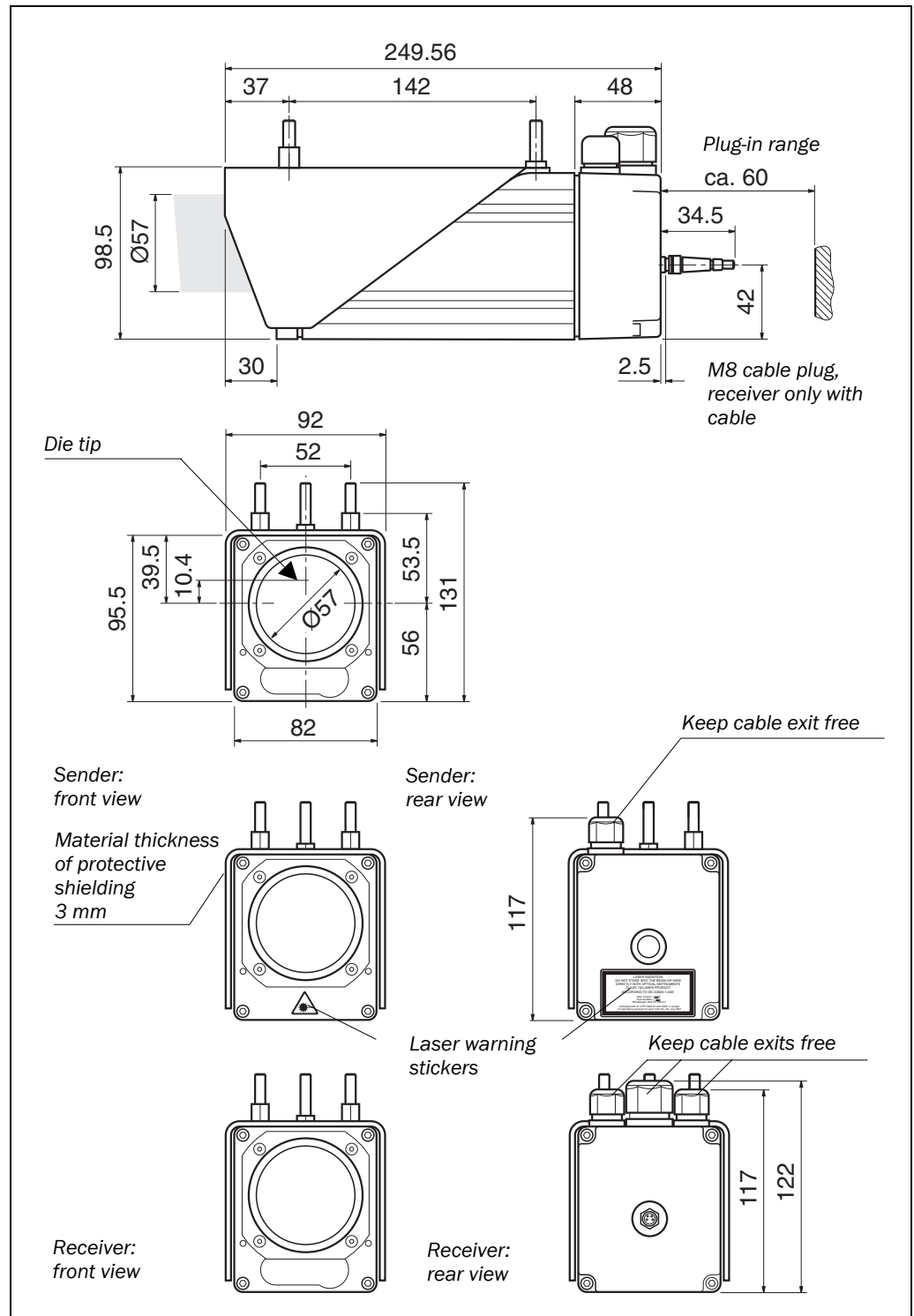

V 4000 PB

10.2.2 SICK mounting kit 1

Fig. 50: Dimensional drawing:
SICK mounting kit 1

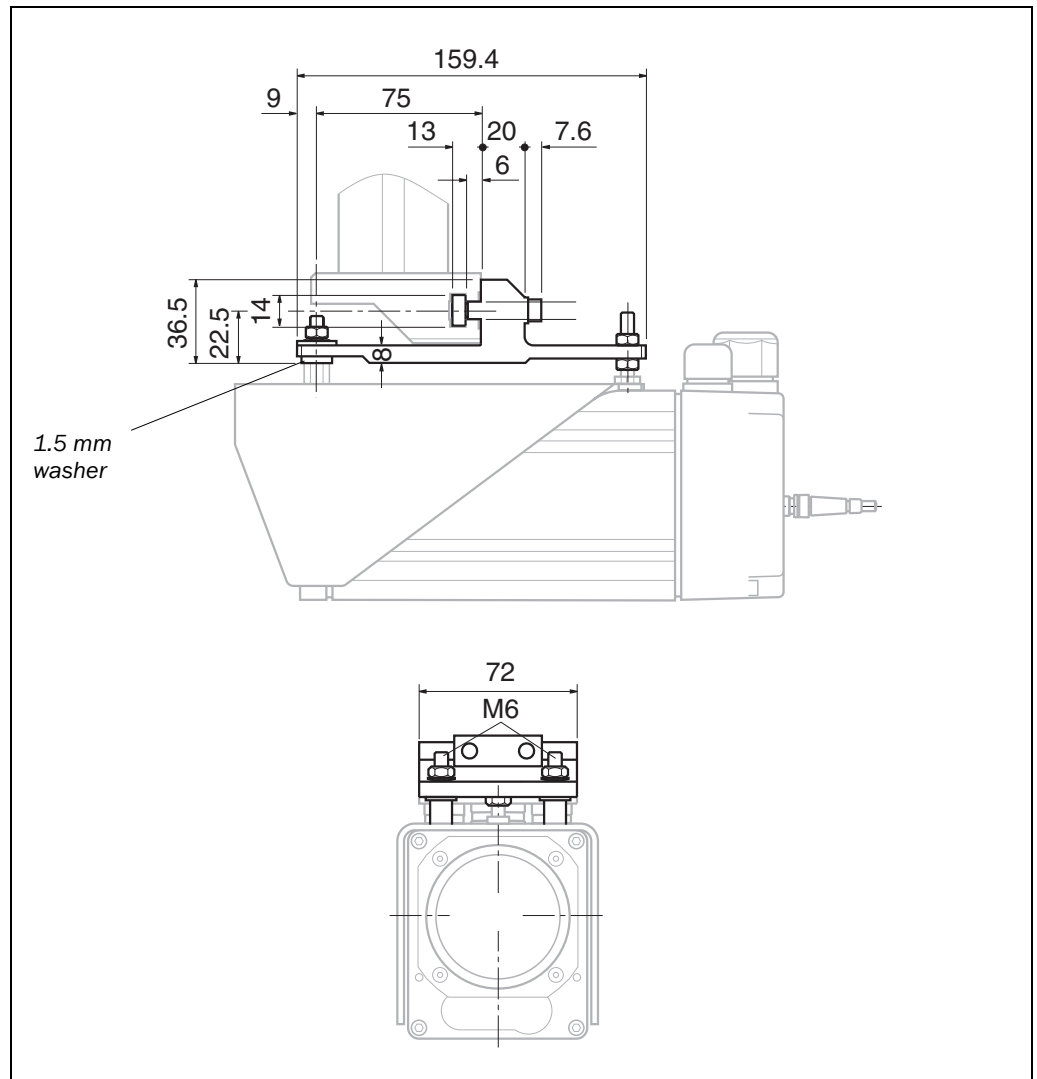

11 Ordering information

11.1 Scope of delivery

- V 4000 PB sender
- or
- V 4000 PB receiver
- Test piece
- Set of masks
- Operating instructions and CDS on CD
- Sticker: Information for **daily inspection**
- Magnetic plate for edge covering

11.2 Available systems

Tab. 35: System part numbers

Device type	Part	Part no.
V40PB	V 4000 PB sender	1 025 765
	V 4000 PB receiver	1 025 766

11.3 Accessories

Tab. 36: Accessories part numbers

Part	Description	Part no.
V40PB plug Set of spares: V40PB receiver plug x 2	16-pin	2 032 052
PBI (press brake interface) PBI (press brake interface)		1 026 798
PBI plug Set of spares: PBI plug x 2	16-pin, with extractor for PBI	2 032 051
Mounting kits Mounting kit 1: Alignment plate x 2		2 031 126
Mounting kit 2: Retaining arm x 2		2 031 745
RS232 service cables Service cable, 2 m	Connecting cable. Connects V 4000 PB and serial interface of the PC M8*4-pin / D-Sub / 9-pin (DIN 41642)	6 021 195
Service cable, 8 m		2 027 649

V 4000 PB

Part	Description	Part no.
Connecting cables (shielded) for self-configuration	100 m rings	
4-pin, sender-receiver, usable as trailing cable, 0.34 mm ²		6 029 221
4-pin, receiver-PBI, 0.34 mm ²		6 029 222
18-pin, receiver-control cabinet, usable as trailing cable, 0.34 mm ²		6 029 223
24 V DC, 2.5 A power supply		6 010 361
Documentation		
CDS (Configuration & Diagnostic Software) on CD incl. on-line documentation and		2 032 314
Operating instructions in all available languages		8 010 501
Set of masks		
Receiver mask, sender mask, press crosshead masks		2 030 829
Miscellaneous		
Plastics cleaning agent	Plastics cleaning and care agent, antistatic, 1 litre	5 600 006
Lens cloth	Cloth for cleaning front lens	4 003 353
Test piece	Test piece for external device monitoring	4 040 724
Magnetic plate	Magnetic plate for covering female die opening beneath the workpiece	4 040 736

12 Glossary

Alignment mode	Operating mode for aligning the protective volume, requested via the corresponding button. This mode supports the operator in aligning the sender to the die and the receiver to the sender following a tooling change.
Blanking	Local deactivation of parts of the protective volume (protective volume segment).
Braking distance	Distance covered by the press brake braking down from the high closing speed to the target speed v_{slow} during a normal braking procedure.
Braking offset	The braking offset is added to the braking distance calculated from the power-up cycle. The gap size when the target speed v_{slow} is reached is increased by the braking offset (see also Section 3.5.9).
Bypass	In bypass mode the press brake can be operated without an activated V 4000 PB protective device.
Bypass mode	Operating mode of the V 4000 PB.
Closing movement	The die is lowered down the pressure axis onto the female die or onto the metal sheet lying on it.
Die	Top tool or male tool of the press brake.
External device monitoring (EDM)	Device which monitors the relays or contactors addressed by the protective device.
Female die	Bottom forming tool of the press brake.
Hazard point	The area beneath the die in which hazards or dangers could occur for the operator.
High closing speed	v_P closing speed of the press ($v > 10$ mm/s).
Illumination field	Illuminated area beneath the die which is demarcated by the optically clear area of the lens.
Image sensor	Optical image sensor. Consists of a large number of light-sensitive image elements (pixels) arranged in a tightly-packed array on a silicon backing element.
Incremental encoder	Sensor for position-sensing which supplies individual increments during a movement (rotation / offset).
Lock-out state	With certain errors or an erroneous configuration, the system will go into the lock-out state.
Maximum closing speed	The highest closing speed of the press brake which depends on the individual machine design.
Muting	Bridging, time-limited suppression of the protection function of the V 4000 PB.
Muting point	Point on the pressure axis from which the protective function of the V 4000 PB is bridged in order to finish the operating cycle without the protective device responding. The muting point is located at a gap size of ≤ 6 mm.
Operating cycle	Movements of the press crosshead of the press brake from the starting position of the cycle (in most cases the top dead centre) to the bottom dead centre and back to the starting position of the cycle. The operating cycle includes all procedures or operations which are carried out during this movement.
Operating mode	Protective operation, alignment mode, configuration, bypass mode.
Operating state	In protective operation the following operating states are available: power-up cycle, teach-in, production mode.
OSSDs	Output switching elements of the V 4000 PB. These elements are electronically monitored.
Overall machine overrun	Distance required, after the stop signal is issued, to stop the hazardous movement.

V 4000 PB

Overall response time	Time between the stop signal (opening of the OSSDs) and when the press brake is at a standstill.
Pinch point	Point on the pressure axis at which the die contacts the sheet metal before bending. Reference point of the V 4000 PB for determining the muting point and switch-over point.
Power-up cycle	Determining the overall machine overrun, the braking distance, complete run following commissioning or a restart of the V 4000 PB. This could be, for example, after restoration of the power supply, or after a reset with teach-in.
Pressure axis	Line along which the workpiece is formed between the male and female dies.
Programmed top dead centre	The top dead centre in the operating cycle which is programmed in the press controller.
Programmed bottom dead centre	The bottom dead centre in the operating cycle which is programmed in the press controller.
Protective volume	The protective volume safeguards the hazardous area beneath the die. As soon as the V 4000 PB detects an object in the protective volume, it switches the OSSDs into the OFF state and thus causes the closing movement to stop. The area within which the defined test piece is detected by the V 4000 PB.
Protective volume mode	In protective operation the following protective volume modes are available: standard mode, box mode, back-stop mode. In box and back-stop modes parts of the protective volume are blanked.
Protective volume segment	Part of the protective volume.
Protective operation	Operating mode of the V 4000 PB. The protective volume is active and there is monitoring for interruption. Position, direction of movement, speed and overall machine overrun are monitored and evaluated (see also Section 3.6).
Rear space	The other side of the press brake opposite to the operator, behind the pressure axis.
Request signal for teach-in	Digital output signal to the press controller.
Request signal for alignment mode	Digital output signal to the press controller.
Request signal v_{slow} Resolution	Digital output signal to the press controller. The smallest size of object which can be detected by the protective device and which is guaranteed by the manufacturer.
Reset	After the V 4000 PB resets, there will be a full system start.
Response time	The maximum time between the occurrence of an event which causes the V 4000 PB to respond and the OSSDs reaching the OFF state.
Restart interlock	Device which inhibits automatic starting of the machine. Switch-over point.
Slow closing speed	v_{crawl} closing speed of the press ($v \leq 10$ mm/s).
Start signal for closing movement	Gated signal from the press controller to the inputs of the V 4000 PB and which is followed by a movement of the press crosshead.
Stopping distance	The stopping distance is a system parameter from the V 4000 PB and the press brake which is defined in the design of the V 4000 PB. The stopping distance S describes the maximum path section which the press brake covers in the time between the sensor function responding and the press coming to a standstill
Switch-over point	Switch-over point is the position on downward motion of the press when the speed begins to change from v_{max} to v_{slow} .

Target speed	v_{slow} closing speed which the press must have reached following the braking procedure.
Teach-in	Determining the pinch point on the surface of the workpiece.
Test piece	Standardised test piece with rod and body sections and used for triggering the sensor function of the V 4000 PB during the function check.

13 Annex

13.1 Detailed system sequences in protective operation

This section provides charts of the operating modes and changes over time in the machine movement, tool speed, states and signals.

Details of the individual signals may be found in the descriptions of the interfaces.

13.1.1 Power-up cycle

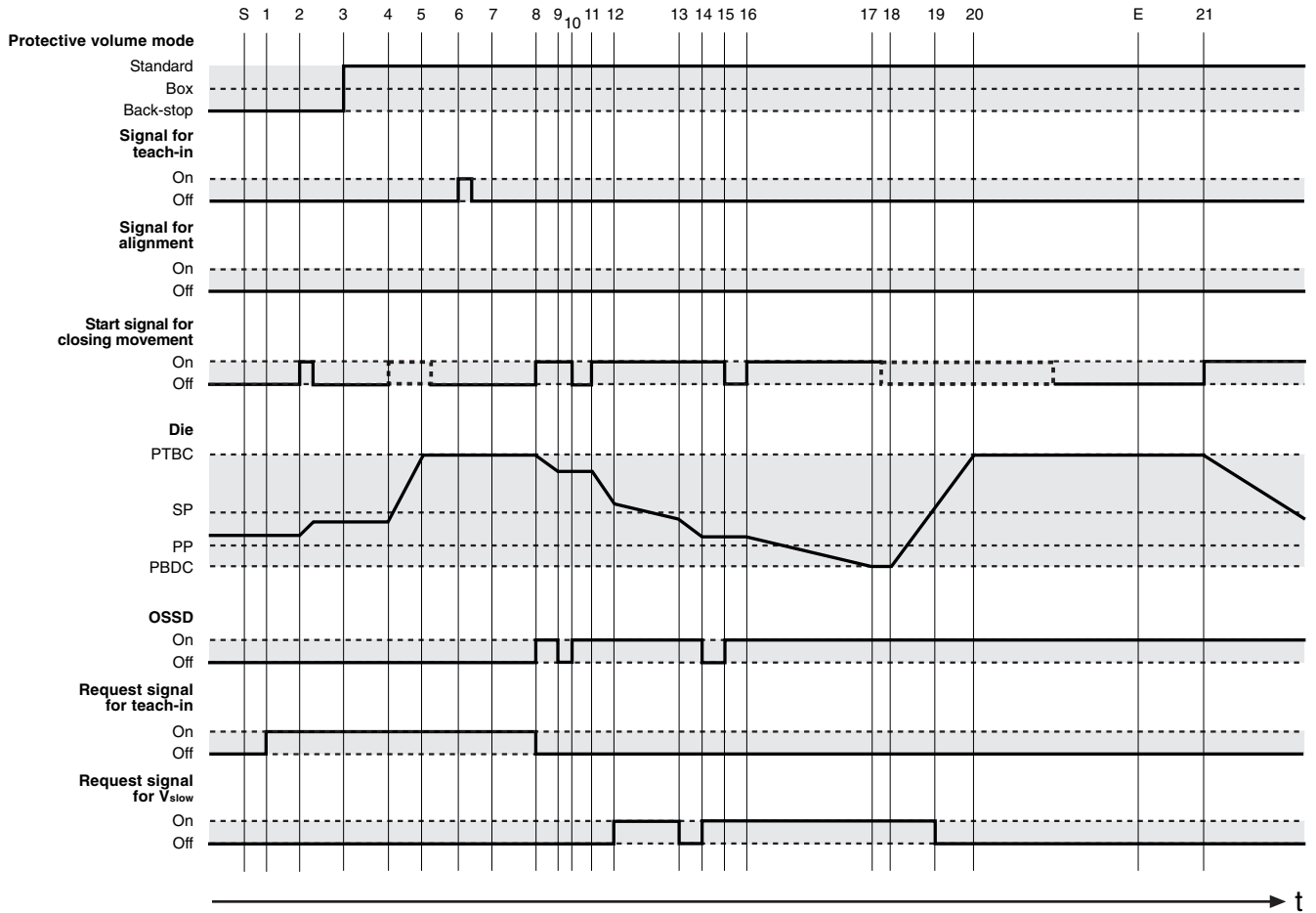

V 4000 PB

Tab. 37: Power-up cycle sequence

t	Description
S	The die is at any position in the operating cycle. The OSSDs are closed. The protective volume is active. Protective volume mode: standard
1	V 4000 PB detects a time-out since the last power-up cycle.
2	The movement stops and the die stops and any position.
3	The operator gives the start signal for the fast closing movement. The start signal has no effect on the V 4000 PB.
4	The press controller or if applicable the operator gives the start signal for opening the press.
5	The opening movement is finished.
6	If standard has been selected, the operator does not need to specifically select the protective volume mode.
7	The operator confirms the teach-in request.
8	The V 4000 PB detects the end of the opening movement.
9	The operator gives the start signal for the fast closing movement.
10	The V 4000 PB switches the OSSDs off. The fast closing movement is aborted. The overall machine overrun is checked.
11	The operator cancels the start signal for the fast closing movement.
12	The operator gives once more the start signal for the fast closing movement.
13	The V 4000 PB requests the target speed.
14	The V 4000 PB detects and accepts the target speed. The V 4000 PB cancels the target speed request.
15	The closing movement is stopped above the pinch point and the overall machine overrun checked.
16	The operator cancels the start signal for the fast closing movement.
17	The operator gives once more the start signal for the closing movement.
18	The press finishes the closing movement.
19	The press controller or if applicable the operator gives the start signal for opening the press.
20	The protective volume is clear.
21	Upon failure to reach the switch-over point the V 4000 PB cancels the request for slow speed.
22	The opening movement is finished.
E	End of the opening movement.

13.1.2 Teach-in

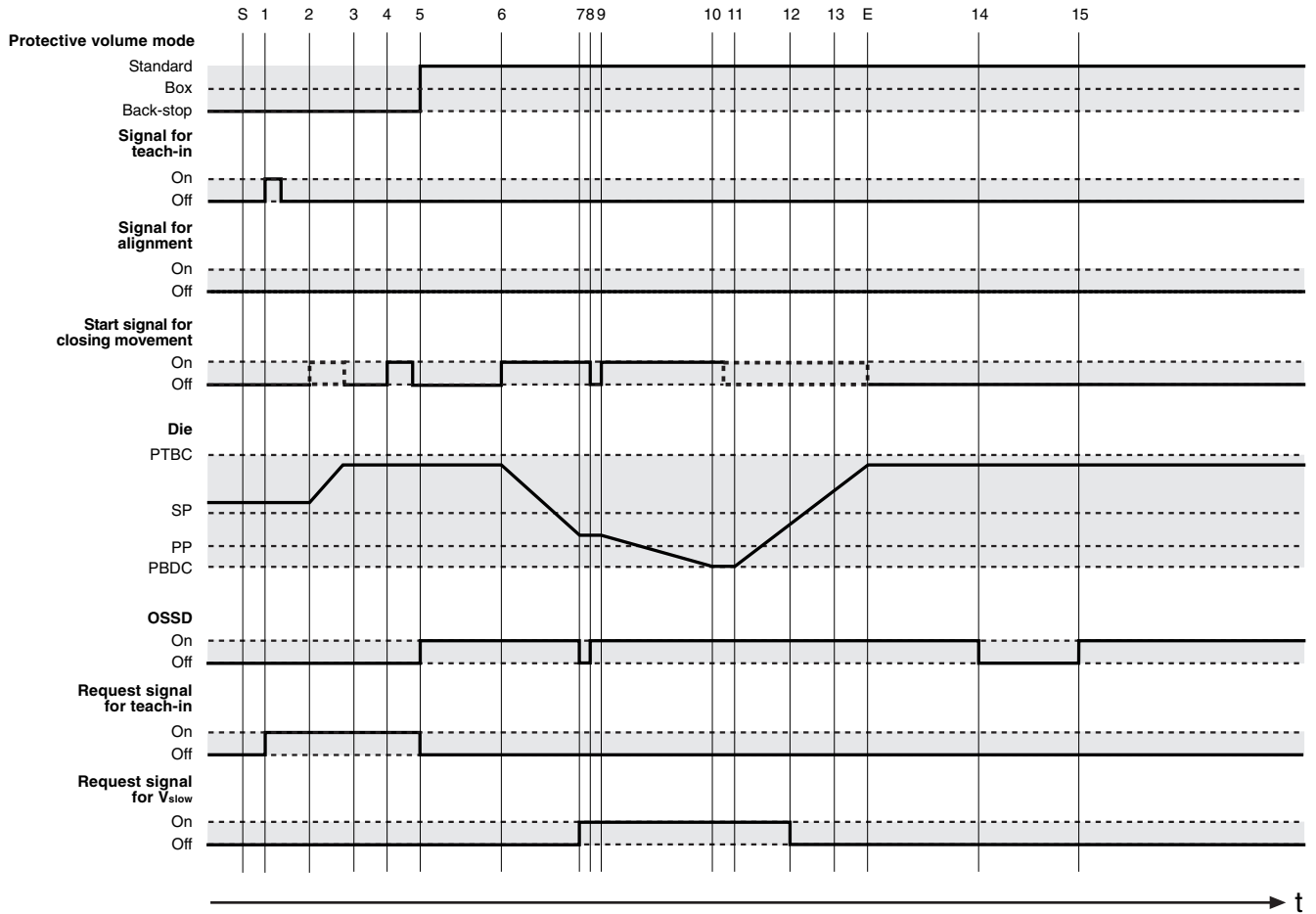

V 4000 PB

Tab. 38: Teach-in request sequence

t	Description
S	The die is at any position in the operating cycle. The OSSDs are closed or open. Protective volume mode: any.
1	The operator makes a teach-in request.
2	The press controller or if applicable the operator gives the start signal for opening the press.
3	The V 4000 PB detects the end of the opening movement.
4	The operator gives the start signal for the fast closing movement. The start signal has no effect on the V 4000 PB.
5	The operator selects the protective volume mode. If the following conditions are met, the OSSDs are switched on: <ul style="list-style-type: none"> • Die above the muting point • Standard selected as protective volume mode at least briefly • No start signal for the fast closing movement.
6	The operator gives the start signal for the fast closing movement.
7	The closing movement is stopped above the pinch point and the overall machine overrun checked.
8	The operator cancels the start signal.
9	The operator gives the start signal for the closing movement.
10	The press finishes the closing movement.
11	The press controller or if applicable the operator gives the start signal for opening the press.
12	Upon passing the switch-over point the V 4000 PB cancels the request for slow speed.
13	The opening movement is finished.
E	Teach-in is completed.
14	Function test by interrupting the active protective volume.
15	Function test finished.

13.1.3 Standard mode

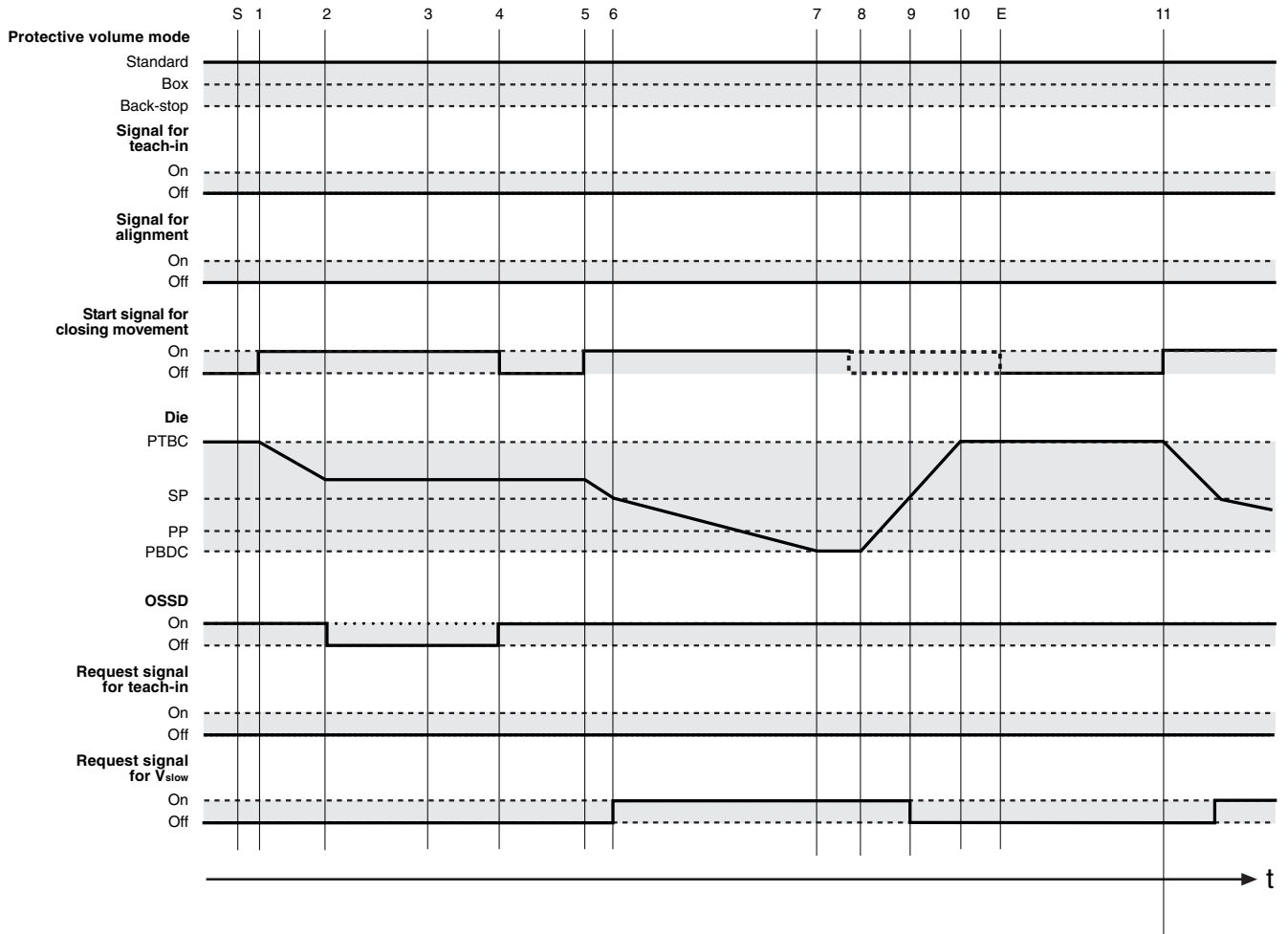

V 4000 PB

Tab. 39: Standard mode sequence

t	Description
S	The die is at the top dead centre. The OSSDs are closed. The protective volume is active. Protective volume mode: standard
1	The operator gives the start signal for the fast closing movement.
2	An object interrupts the protective volume.
3	The object is removed from the protective volume. The protective volume is clear again.
4	The operator cancels the start signal for the fast closing movement.
5	The operator gives once more the start signal for the fast closing movement.
6	The V 4000 PB requests the target speed.
7	The press finishes the closing movement.
8	The press controller or if applicable the operator gives the start signal for opening the press.
9	Upon passing the switch-over point the V 4000 PB cancels the request for slow speed.
10	The opening movement is finished.
E	The operating cycle is completed.
11	A new operating cycle is started.

13.1.4 Box or back-stop mode with interruption of the protective volume

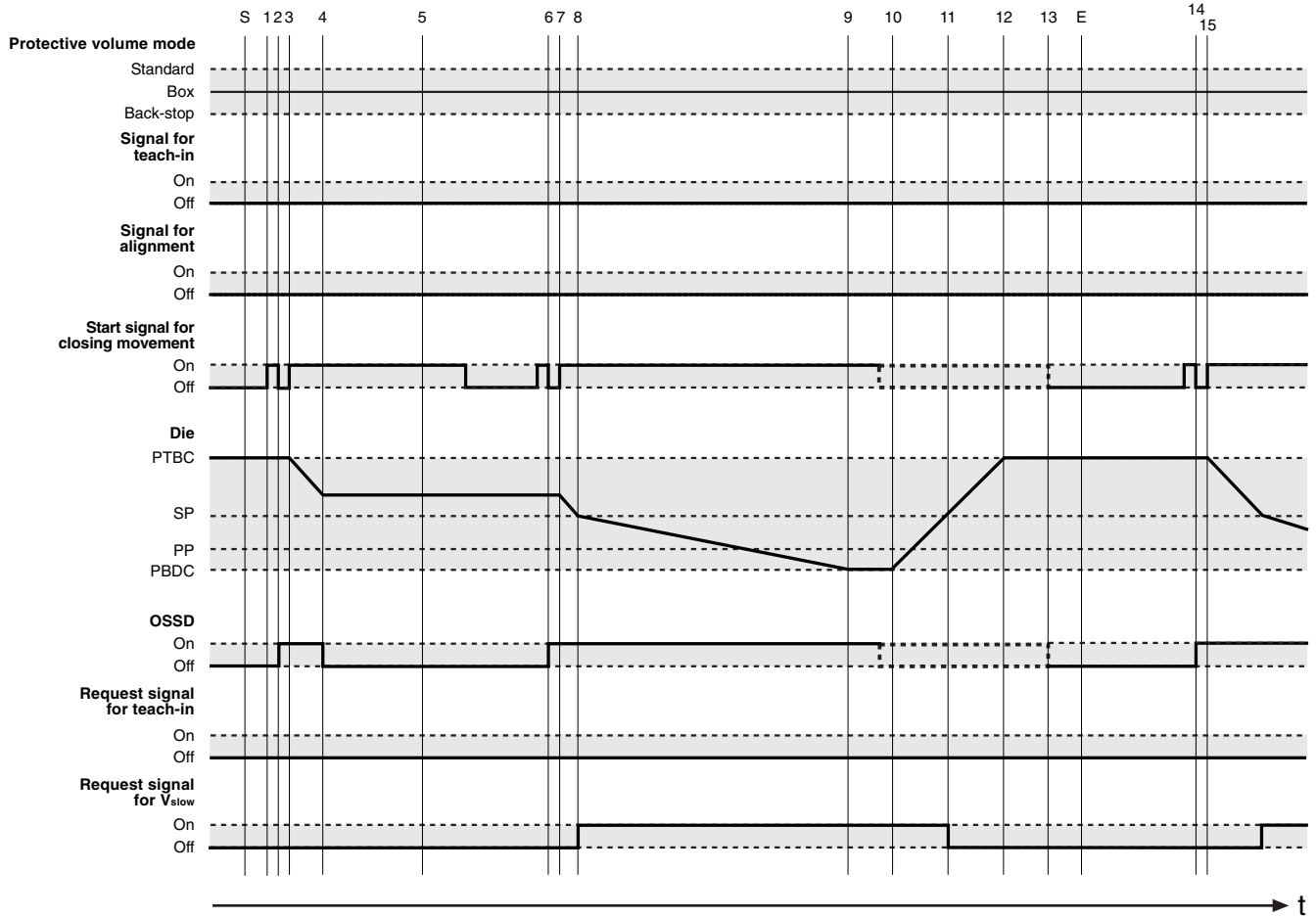

V 4000 PB

Tab. 40: Box or back-stop mode sequence

t	Description
S	The die is at the top dead centre. The OSSDs are closed. The protective volume is active. Protective volume mode: box or back-stop
1	The operator confirms box or back-stop as the protective volume mode.
2	The operator cancels the protective volume mode confirmation.
3	The operator gives the start signal for the fast closing movement.
4	An object interrupts the protective volume.
5	The object is removed from the protective volume. The protective volume is clear again.
6	The operator cancels the start signal for the fast closing movement.
7	The operator gives once more the start signal for the fast closing movement.
8	The V 4000 PB requests the target speed.
9	The press finishes the closing movement.
10	The press controller or if applicable the operator gives the start signal for opening the press.
11	Upon passing the switch-over point the V 4000 PB cancels the request for slow speed.
12	The opening movement is finished.
13	Upon the start request disappearing the OSSDs are switched off.
E	The operating cycle is completed.
14	The operator cancels, if applicable, the start signal for opening the press.
15	A new operating cycle is started.

13.2 Declaration of Conformity

SICK

EC Declaration of conformity

en

Ident-No. : 9093200

The undersigned, representing the following manufacturer

SICK AG
Industrial Safety Systems
Sebastian-Kneipp-Straße 1
79183 Waldkirch
Germany

herewith declares that the product

V4000 press brake

is in conformity with the provisions of the following EC directive(s) (including all applicable amendments), and that the standards and/or technical specifications referenced overleaf have been applied.

Waldkirch, 21.10.09

.....
ppa. Dr. Plasberg
(Manager Research and Development
Industrial Safety Systems)

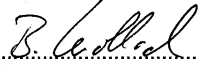
.....
i.V. Knobloch
(Manager Production
Industrial Safety Systems)

V 4000 PB

SICK

EC Declaration of conformity

en

Ident-No. : 9093202

The undersigned, representing the following manufacturer

SICK AG
Industrial Safety Systems
Sebastian-Kneipp-Straße 1
79183 Waldkirch
Germany

herewith declares that the product

PBI

is in conformity with the provisions of the following EC directive(s) (including all applicable amendments), and that the standards and/or technical specifications referenced overleaf have been applied.

Waldkirch, 22.10.14

ppa. Dr. Plasberg
ppa. Dr. Plasberg
(Manager Research and Development
Industrial Safety Systems)

i.V. Knobloch
i.V. Knobloch
(Manager Production
Industrial Safety Systems)

13.3 Manufacturer's checklist

SICK

Checklist for the manufacturer or installer for the installation of electro-sensitive protective equipment (ESPE)

The specifications for the following items listed must be available at least for the initial commissioning but depending on the application, whose requirements the manufacturer or installer must check.

This checklist should be retained/stored with the machine documentation so that you can use it as a reference for periodical tests.

- | | | |
|---|------------------------------|-----------------------------|
| 1. Have the safety rules and regulations been observed in compliance with the directives/standards applicable to the machine? | Yes <input type="checkbox"/> | No <input type="checkbox"/> |
| 2. Are the applied directives and standards listed in the declaration of conformity? | Yes <input type="checkbox"/> | No <input type="checkbox"/> |
| 3. Does the protective device comply with the required control category? | Yes <input type="checkbox"/> | No <input type="checkbox"/> |
| 4. Is access to the hazardous point only possible through the protective volume of the ESPE? | Yes <input type="checkbox"/> | No <input type="checkbox"/> |
| 5. Have additional mechanical protective measures preventing anyone reaching around been fitted and safeguarded against tampering? | Yes <input type="checkbox"/> | No <input type="checkbox"/> |
| 6. Have the ESPE devices been fastened in place properly and once aligned, secured against moving? | Yes <input type="checkbox"/> | No <input type="checkbox"/> |
| 7. Are the required protective measures against electric shock in effect (protection class)? | Yes <input type="checkbox"/> | No <input type="checkbox"/> |
| 8. Are the outputs of the ESPE (OSSDs) integrated in compliance with the required control category and does the integration correspond to the circuit diagrams? | Yes <input type="checkbox"/> | No <input type="checkbox"/> |
| 9. Has the protective function been checked in compliance with the test notes in this documentation? | Yes <input type="checkbox"/> | No <input type="checkbox"/> |
| 10. Are the given protective functions effective at every setting of the operating mode selector switch? | Yes <input type="checkbox"/> | No <input type="checkbox"/> |
| 11. Are the switching elements activated by the ESPE, e.g. contactors, valves monitored? | Yes <input type="checkbox"/> | No <input type="checkbox"/> |
| 12. Is the ESPE effective over the entire period of the dangerous state? | Yes <input type="checkbox"/> | No <input type="checkbox"/> |
| 13. Once initiated, will a dangerous state be stopped when switching the ESPE on or off and when changing the operating mode, or when switching to another protective device? | Yes <input type="checkbox"/> | No <input type="checkbox"/> |
| 14. Is the information label concerning daily inspections posted so that the operator can see it easily? | Yes <input type="checkbox"/> | No <input type="checkbox"/> |
| 15. Have you made sure that the protective device itself when mounted is not a source of danger during machine operation (for example, catching between the device and parts of the machine)? | Yes <input type="checkbox"/> | No <input type="checkbox"/> |

This checklist does not replace initial commissioning and regular tests by specialist personnel.

13.4 List of tables

Tab. 1:	Overview of disposal by component.....	17
Tab. 2:	Display at the sender	25
Tab. 3:	Key to the LEDs on the receiver display.....	26
Tab. 4:	Key to the 7-segment display on the receiver.....	27
Tab. 5:	Inputs and outputs at the digital interface.....	28
Tab. 6:	Display at the PBI	30
Tab. 7:	Configurable parameters and functions	33
Tab. 8:	Braking offset	37
Tab. 9:	Pin assignment of digital interface.....	65
Tab. 10:	Pin assignments of the sender	67
Tab. 11:	Cable glands	68
Tab. 12:	Cable cross-sections.....	68
Tab. 13:	Pin assignments of the PBI	69
Tab. 14:	Pin assignment of permanent configuration connection with RS-422.....	72
Tab. 15:	Pin assignments of temporary configuration connection with RS-232	72
Tab. 16:	Adjustment directions	77
Tab. 17:	Display during alignment of sender and receiver	80
Tab. 18:	Regular checks	87
Tab. 19:	Displays during the power-up cycle	89
Tab. 20:	Protective volume mode displays.....	90
Tab. 21:	Carrying out a power-up cycle, for example in standard mode.....	90
Tab. 22:	Carrying out teach-in, for example in standard mode	92
Tab. 23:	Error displays of the sender LED	95
Tab. 24:	Error displays of the receiver LEDs.....	95
Tab. 25:	Error displays of the 7-segment display	96
Tab. 26:	V 4000 PB general specifications	100
Tab. 27:	V 4000 PB general specifications (cont'd).....	101
Tab. 28:	V 4000 PB general system data	102
Tab. 29:	V 4000 PB electrical specifications.....	102
Tab. 30:	V 4000 PB electrical specifications (cont'd)	103
Tab. 31:	V 4000 PB electrical specifications (cont'd)	104
Tab. 32:	V 4000 PB electrical specifications (cont'd)	105
Tab. 33:	PBI technical data.....	106
Tab. 34:	Technical data of decodable incremental encoders	107
Tab. 35:	System part numbers.....	110
Tab. 36:	Accessories part numbers	110
Tab. 37:	Power-up cycle sequence.....	117
Tab. 38:	Teach-in request sequence.....	119
Tab. 39:	Standard mode sequence.....	121
Tab. 40:	Box or back-stop mode sequence	123

13.5 List of illustrations

Fig. 1:	Warning regarding laser class 1M	11
Fig. 2:	Handling of the workpiece 1.....	13
Fig. 3:	Handling of the workpiece 2.....	13
Fig. 4:	Handling of pre-flanged sheets	14
Fig. 5:	Handling of box-shaped workpieces	15
Fig. 6:	Press brake with V 4000 PB.....	19
Fig. 7:	Definitions	20
Fig. 8:	Components	24
Fig. 9:	Sender and receiver.....	24
Fig. 10:	Display at the sender	25
Fig. 11:	Displays at the receiver	26
Fig. 12:	PBI (press brake interface).....	29
Fig. 13:	Display at the PBI.....	30
Fig. 14:	System configuration with PC control	31
Fig. 15:	System configuration without PC control.....	31
Fig. 16:	Incremental encoder signals.....	36
Fig. 17:	Settling times	40
Fig. 18:	Discrepancy times.....	41
Fig. 19:	Start signal (double-click)	41
Fig. 20:	Protective volume in standard mode.....	44
Fig. 21:	Reduced protective volume in box mode	45
Fig. 22:	Reduced protective volume in back-stop mode.....	46
Fig. 23:	Definitions	47
Fig. 24:	Groove for accommodating the sliding nut	61
Fig. 25:	Mounting using SICK mounting kit 1	62
Fig. 26:	SICK mounting kit 2	63
Fig. 27:	Pin assignments of digital interface.....	64
Fig. 28:	Connection diagram for receiver.....	66
Fig. 29:	OSSDs connection	66
Fig. 30:	Pin assignments of the sender.....	67
Fig. 31:	Pin assignments of the PBI.....	68
Fig. 32:	PBI connection diagram.....	70
Fig. 33:	Bypass connection diagram	71
Fig. 34:	Pin assignments for configuration interface	72
Fig. 35:	Switch setting.....	73
Fig. 36:	Die segments	76
Fig. 37:	Alignment masks.....	76
Fig. 38:	Adjustment directions.....	77
Fig. 39:	Fitting masks A and B	77
Fig. 40:	Alignment in directions I and II.....	78
Fig. 41:	Fitting mask B	78

V 4000 PB

Fig. 42: Alignment in directions III and IV	79
Fig. 43: Alignment of the receiver	80
Fig. 44: Tracking without latching marks.....	82
Fig. 45: Test piece.....	84
Fig. 46: Function check with test rod.....	85
Fig. 47: Function check with test piece (10 mm).....	86
Fig. 48: Function check with test piece (15 mm).....	86
Fig. 49: Dimensional drawings: sender and receiver.....	108
Fig. 50: Dimensional drawing: SICK mounting kit 1.....	109

13.6 Index

A

Alignment	27, 60, 75, 94
display during	80
following a tool change	82
initial alignment	75
Alignment mode	60
request signal for	113
Application	
range of use	23
Application name	34

B

Back-stop mode	46, 58
bending in	93
Baking distance	
travel for determining the	37
Blanking	112
Box mode	45, 56
bending in	93
Braking distance	112
default value	36
target speed v_{slow} for	
determining the	37
Braking offset	37, 112
Bypass	112
Bypass-mode	112
configuration	41, 42
connection	71

C

CDS (Configuration & Diagnostics	
Software)	30
Changing the sheet thickness	93
Check	
daily	87, 89
function check	84
regular	87
Cleaning	94
Closing movement	112
Closing speed	
high	47, 112
maximum	38, 112
slow	47, 113

Configuration	73
CDS (Configuration & Diagnostics	
Software)	30
configuration connection	72
delivery state	73
possible configurations	32
preparations	74
serial interface for	28
Configuration connection	72
baud rate	34
Connection See electrical	
installation	

D

Dead centre	
bottom	47, 113
top	39, 47, 113
Diagnostics	
serial interface for	28
via CDS	98
Die	112
Discrepancy times	41
Disposal	17

E

Electrical installation	64
bypass	71
configuration connection	72
external device monitoring (EDM) ..	70
making up the connections	68
PBI	68
receiver	64
sender	67
Explosion protection	101
External device	
monitoring (EDM)	112
configuration	36
connection	70
Extraneous light	101

V 4000 PB**F**

Female die	112
Function check	84
test piece	114
with test piece	86
with test rod	85

H

Hazard point	112
--------------------	-----

I

Illumination field	112
Image sensor	112
Incremental encoder	112
Incremental encoders	
incremental measurement guides ..	29
resolution	35

Inputs

discrepancy time	41
settling time	40

Interfaces

at the PBI	30
at the receiver	27

L

Latching marks	83
Lock-out state	95, 112

M

Malfunctions See remedying errors	
Mounting	61
Muting	112
speed dependent	35
Muting point	112

O

Operating elements	32
Operating mode	112
Operating signals	9
Operator signals	34
OSSDs	19, 25, 28, 112
Switch-off time	42
Outputs	
safety relevant, switch-off time	42
state time	42

Overall machine overrun	112
maximum	38
travel for determining the	39

P

PBI (press brake interface)	29
interface at	30
interfaces for connecting the	28
PBI (Press brake interface)	
connection	68
Pinch point	113
teach-in	113
Position-sensing system	35
Power-up cycle	48, 113
carrying out	90
displays during the	89
Pressure axis	113
Protection principle	19
Protective operation	18, 43, 113
Protective volume	113
during the operating cycle	21
reduced	41, 45, 46
with an interruption	22
Protective volume mode	113
back-stop mode	46, 58, 122
box mode	45, 56, 122
selecting	90
standard mode	54, 120
Standard mode	44
Protective volume segment	113
R	
Rear space	113
Receiver	24
alignment	80
connection	64
digital interface	28
displays at	26
serial interface	28, 34

Remedying errors	95	Start signal	113
diagnostics via the CDS	98	State time	42
error displays of the		Stopping distance	39, 113
7-segment display	96	Support	99
error displays of the LEDs	95	Switching on	
response to errors and		carrying out a power-up cycle	90
malfunctions	95	carrying out power-up cycle	94
Reset	113	machine	89
Resetting	90	power-up cycle	43
Resolution	113	Switch-off time	42
Response time	113	Switch-over point	113
Restart interlock	113	System configuration	31
S		T	
Sender	24	Target speed	37, 47, 114
alignment	77	request signal	113
connection	67	Teach-in	44, 52, 114, 118
display at	25	carrying out	92
interface for connecting the	28	request signal for	113
Settling times	40	Tool-changing	94
Standard mode	44, 54	W	
bending in	93	Workpiece	
Standstill detection	40	correct handling	12
Start delay	39		

Contact:

Australia

Phone +61 3 9497 4100
1800 33 48 02 – tollfree
E-Mail sales@sick.com.au

Belgium / Luxembourg

Phone +32 (0)2 466 55 66
E-Mail info@sick.be

Brasil

Phone +55 11 5091-4900
E-Mail sac@sick.com.br

Ceská Republika

Phone +420 2 57 91 18 50
E-Mail sick@sick.cz

China

Phone +852-2763 6966
E-Mail ghk@sick.com.hk

Danmark

Phone +45 45 82 64 00
E-Mail sick@sick.dk

Deutschland

Phone +49 (0)2 11 53 01-260
E-Mail vzdinfo@sick.de

España

Phone +34 93 480 31 00
E-Mail info@sick.es

France

Phone +33 1 64 62 35 00
E-Mail info@sick.fr

Great Britain

Phone +44 (0)1727 831121
E-Mail info@sick.co.uk

Italia

Phone +39 02 27 40 93 19
E-Mail ced@sick.it

Japan

Phone +81 (0)3 3358 1341
E-Mail info@sick.jp

Korea

Phone +82-2 786 6321/4
E-Mail kang@sickkorea.net

Netherlands

Phone +31 (0)30 229 25 44
E-Mail info@sick.nl

Norge

Phone +47 67 81 50 00
E-Mail austefjord@sick.no

Österreich

Phone +43 (0)22 36 62 28 8-0
E-Mail office@sick.at

Polska

Phone +48 22 837 40 50
E-Mail info@sick.pl

Schweiz

Phone +41 41 619 29 39
E-Mail contact@sick.ch

Singapore

Phone +65 6744 3732
E-Mail admin@sicksgp.com.sg

Suomi

Phone +358-9-25 15 800
E-Mail sick@sick.fi

Sverige

Phone +46 8 680 64 50
E-Mail info@sick.se

Türkiye

Phone +90 216 388 95 90 pbx
E-Mail info@sick.com.tr

Taiwan

Phone +886 2 2365-6292
E-Mail sickgrc@ms6.hinet.net

USA / Canada / Mexico

Phone +1(952) 941-6780
1 800-325-7425 – tollfree
E-Mail info@sickusa.com

More representatives and agencies
in all major industrial nations at
www.sick.com

SICK

SICK AG • Industrial Safety Systems • Waldkirch • Germany • www.sick.com